

Pony Club®

Where it all begins



Games Rulebook

2021

THE USPC PLEDGE

*As a Member of the United States Pony Club,
I stand for the best in sportsmanship as well as in horsemanship.
I shall compete for the enjoyment of the game well played and
take winning or losing in stride, remembering that without good
manners and good temper, sport loses its cause for being.
I shall endeavor to maintain the best tradition of the ancient and
noble skill of horsemanship, always treating my horse
with consideration due a partner.*

USPC MISSION STATEMENT

The United States Pony Clubs, Inc. develops character, leadership, confidence, and a sense of community in youth through a program that teaches the care of horses and ponies, riding and mounted sports.

Introduction

Mounted Games were originally the idea of His Royal Highness, Prince Philip, as a way to encourage enthusiasm, participation, and training in younger riders without the need of expensive ponies. A natural draw to all levels of riding abilities, Games provide a fun sport that teaches the basic natural aids, physical coordination, self-confidence, and teamwork skills. It also fosters sportsmanship and the proper care of mounts in new and younger members.

Competitions

Mounted Games competitions are comprised of several relay-style races requiring riders to pick up objects from the ground while remaining in the saddle, weave through a series of poles at high speeds, hand items off to teammates without slowing their ponies, and dunking objects into buckets (sometimes at a gallop!). Teams are made up of two to five riders of the same skill level.

Ponies are the preferred mount of choice for games as their shorter stature make several of the races much easier to play. Horses can be used but are much harder for riders to reach the ground from while remaining in the saddle and can be more difficult to mount/dismount at faster paces than a walk or standstill.

USPC CORE VALUES

Horsemanship with respect to healthcare, nutrition, stable management, handling and riding a mount safely, correctly and with confidence.

Organized teamwork including cooperation, communication, responsibility, leadership, mentoring, teaching and fostering a supportive yet competitive environment.

Respect for the horse and self through horsemanship; for land through land conservation; and for others through service and teamwork.

Service by providing an opportunity for members, parents, and others to support the Pony Club program locally, regionally and nationally through volunteerism.

Education at an individual pace to achieve personal goals and expand knowledge through teaching others.

Riders of any skill level and ability can compete in Mounted Games, with beginners usually competing at the Walk-Trot level before moving on into the Novice, Junior, Senior, and Advanced ranks. The levels are divided based on the ages of the riders, with the exception of Walk-Trot in which any member of any age can compete.

Mounted Games in Pony Club

As one of Pony Club's most popular disciplines, Mounted Games provides members of all ages and ability with a fun, fast-paced activity that teaches riding skills in an exciting and teamwork-driven environment. Members compete on teams of four or five riders and have several opportunities to compete both nationally and internationally. Pony Club puts on games exhibitions with the Prince Philip Cup at the Kentucky Three-Day Event and the President's Cup. An International Exchange is also offered to some of the best Mounted Games riders in Pony Club, allowing them to travel and experience Games in countries such as England, Australia and Canada.

© 2021 The United States Pony Clubs, Inc. (USPC)

4041 Iron Works Parkway, Lexington, Kentucky 40511-8462 • (859) 254-7669 • Fax (859) 233-4652
Copying permitted for internal use only by members and volunteers of The United States Pony Clubs

TABLE OF CONTENTS

SECTION I: USPC Rally Uniform Officiation Rules (UOR)

Article 1—Rally Definition	1
Article 2—Governing Rules	1
Article 3—Responsibility	1
Article 4—Legal Liability	1
Article 5—Member Participation and Eligibility	2
Article 6—Member in Good Standing	2
Article 7—Code of Conduct Expectations	2
Article 8—Human Substances and Weapons Policy	2
Article 9—Mounts	2
Article 10—Substitution of Mounts	3
Article 11—Sharing of Mounts	3
Article 12—Equine Drugs & Medication	3
Article 13—Cruelty to and Abuse of a Mount	3
Article 14—Dangerous Riding	4
Article 15—Safety	5
Article 16—Heat Related Information	5
Article 17—Concussion and Return to Play	6
Article 18—Unauthorized Assistance and Permitted Assistance in all Phases	6
Article 19—Excused	7
Article 20—Elimination	7
Article 21—Disqualification	7

SECTION II: General Regulations

Chapter 1—Team Composition

Article 22—Team Formation	8
Article 23—Team Configuration	8
Article 24—Team Captains	8
Article 25—Mount Specifications	9
Article 26—Chaperones/Emergency Contacts	9
Article 27—Coaches and Coaching	9

Chapter 2—Competition Levels and Divisions

Article 28—Competition Levels	10
Article 29—Competition Divisions	10
Article 30—Championships Divisions—Minimum Age and Certifications	10
Article 31—Championships Eligibility Process	10
Article 32—Eligibility Requirements for B/A Certified Competitors	11
Article 33—Exceptions to Eligibility Requirements for Championships	11

Chapter 3—Presentation of Competitor and Mount

Article 34—Competitor Identification	11
Article 35—Competitor Attire	11
Article 36—Bits, Saddlery and Equipment	12
Article 37—Competitor and Horse Inspections	13

SECTION III: Competition

Article 38—Competition Format	15
Article 39—Competition Schedule	15

Chapter 1—Arenas and Judging

Article 40—Arena Specifications	15
Article 41—Warm-Up Area	16
Article 42—Access to Arena	16
Article 43—Execution and Judging of Games	16

Chapter 2—Playing of Games

Article 44—Start	17
Article 45—Changeover	17
Article 46—Results of Race	17
Article 47—Rotation	18
Article 48—Tie	18
Article 49—Saddlery During Game	18
Article 50—Error in Race	18

Chapter 3—Types of Games

Article 51—Games for 4-5 Rider Team Competition	19
Article 52—Games for Pairs Competition	35

SECTION IV: Scoring

Article 53—Points and Penalties	51
Article 54—Inquiries, Protests and Appeals	51
Article 55—Scoring of Excused	52
Article 56—Scoring of Elimination	52
Article 57—Scoring of Disqualification	52
Article 58—Team Scoring	53
Article 59—Posting Scores	53
Article 60—Placing of Teams	53

SECTION V: Officiation

Article 61—Rally Organizer	54
Article 62—Technical Delegate (TD)	54
Article 63—Discipline Ground Jury	54
Article 64—President of the Discipline Ground Jury	55
Article 65—Overall Ground Jury/Appeals Committee (for Multiple Championships)	55
Article 66—Horse Management Judges	55
Article 67—Chief Horse Management Judge (CHMJ)	55
Article 68—Line Judges	55
Article 69—Lane Judges	55
Article 70—The Judging Committee	55
Article 71—Chief Overall Judges	56
Article 72—Official's Equipment	56
Article 73—Inspection Panel	56
Article 74—Veterinarian	56
Article 75—Chief Scorekeeper	56
Article 76—Required Medical Personnel	56

TABLE OF CONTENTS

SECTION VI: Appendices

Appendix I	Mounted Competitions Scoring Inquiry/Protest/Appeal Form	57
Appendix II	Heat Illness and Heat Index Chart	59
Appendix III	Chaperone and Emergency Contact Forms	60
Appendix IV	Junior/Senior Team Formation	63
Appendix V	USPC Games Rally Technical Delegate Evaluation and Report	64
Appendix VI	Games Coaches Form and Guidelines	67
Appendix VII	Games Yellow (Warning) Card	68
Appendix VIII	Examples of Approved and Unapproved Bits for USPC Mounted Games Rally	69
Appendix IX	Algorithm for Formation of Games Teams	71
Appendix X	Mount/Rider Weight Requirements	73

Resource List

- USPC website www.ponyclub.org
- USPC Games web page www.ponyclub.org/Members/Disciplines/Games
- USPC Games Facebook Page www.facebook.com/GamesinUSPC
- USPC International Mounted Games Exchange Facebook Page www.facebook.com/USPCIMGE

Reminder: This is a new rulebook for 2021. Additions, deletions and changes have been made since the last rulebook was issued. Be sure to read the *entire* publication carefully so you will be aware of all the rules for the upcoming rally season.

This rulebook should be kept in a 3-ring binder to allow for addition of revisions and new instructional sections. Do not remove pages from your rulebook; be sure to make copies of all forms and charts before writing on them.

These rules are based on copyrighted Rules of the U.S. Equestrian Federation and are printed with the permission of the USEF, which neither sponsors nor is responsible for their publication or implementation at any United States Pony Club event.

SECTION I—USPC Rally Uniform Officiation Rules (UOR)

Article 1—Rally Definition

A Pony Club rally is defined as a team competition (whenever possible) where a team's achievement is emphasized whether competing unmounted or mounted. A rally may take place all in one day or may span several days of competition. Any rally may be held within the framework of a local or recognized show.

This rulebook is intended to establish standards for United States Pony Clubs (USPC) rallies while allowing variety in the types of competitions. Organizers of competitions should work with their regional supervisors (RS) to offer the levels and divisions that they feel are appropriate for the local needs. It is the responsibility of the organizer and regional supervisor to offer the appropriate standard or modified rallies and divisions that meet the needs of their members wishing to become eligible for Championships. Regions may host more than one rally per discipline in the same year. In modified rallies and divisions, this rulebook is to be considered a guide and rules may be adjusted. Any adjustments must be outlined in the entry information. Criteria for standard and modified rallies is listed below.

Standard Rallies

Standard rallies are always preferred. These rallies specifically follow all the rules outlined in the discipline rulebooks including utilizing a chief horse management judge (CHMJ) from the approved CHMJ list on the USPC website, and any other specified licensed officials. Certain divisions of Championships require the member attend a standard rally, and attendance at a standard rally and meeting minimum eligibility requirements guarantee a members' ability to attend Championships.

Modified Rallies

Modified rallies do not specifically follow the discipline rulebooks and generally occur because of limited resources. While attendance of a modified rally makes some members eligible for the modified divisions of Championships, it does not meet the minimum eligibility requirements for other divisions.

Each year, every region should host rallies and is encouraged to work cooperatively with other regions to host joint rallies as appropriate. At all levels, organizers are encouraged to keep rallies simple and inexpensive. Local and regional rallies are team competitions involving club/centers from only one region. Inter-regional rallies are team competitions between two or more regions. Championships are national rallies organized by USPC and the discipline committee that occur annually in varying locations. Visit the USPC website for specific details about upcoming Championships dates and locations.

If an individual's region does not offer a rally in the desired discipline, they may earn eligibility in another region upon obtaining approval from the RS in both regions.

Rally competitions are normally competed in as teams, but sometimes members compete as individuals based on the needs of the hosting group. In all rallies, teams should be recognized for their achievements in the competition. In mounted rallies, team/competitor placings will be based on a combination of their riding scores and their horse management scores. Separate horse management awards are often given for the team/individual achieving the lowest horse management penalties during the rally.

Article 2—Governing Rules

With regards to standard rallies, this rulebook is a precise specification of rules that must be followed. For modified rallies/divisions/cometitors, this rulebook should be viewed as a guide that can be adjusted by the rally organizer/regional supervisor to best meet the needs of the region. Modifications should be listed in the rally entry information. Additional governing documents for all rallies are the following:

- Annual Discipline Newsletters
- USPC Horse Management Handbook (current edition)
- Official Amendments and Clarifications from USPC
- Appropriate parent organization rulebooks (i.e. USEF, APA). If the rally is being run in conjunction with a recognized event, the parent organization rulebook will supersede this rulebook. If the rally is not being run in conjunction with a recognized event, then this rulebook will be followed.

Since rules cannot provide for every eventuality (unforeseen or exceptional circumstance), it is the obligation of the discipline ground jury to make decisions in a sporting spirit and to follow as closely as possible the intention of these rules. If there is an inconsistency, the discipline rulebook takes precedence over the Horse Management Handbook.

These rules are based on copyrighted rules of the U.S. Equestrian Federation (USEF) and are printed with the permission of USEF, which neither sponsors nor is responsible for their publication or implementation at any USPC event.

Article 3—Responsibility

A competitor is ultimately responsible for knowing these rules and complying with them. The appointment of an official, whether or not provided for in these rules, does not absolve the competitor from such responsibility.

Article 4—Legal Liability

Neither the USPC, host club/center/region(s), the organizer, competition officials, staff, nor any other person acting on behalf of the organizer, shall be held liable for any loss,

SECTION I—USPC Rally Uniform Officiation Rules (UOR)

damage, accident, injury or illness to competitors, mounts or to any other person or property whatsoever.

Article 5—Member Participation and Eligibility

Participation in Rallies:

At local, regional, and inter-regional rallies, participants may be of any age or certification, must be a member in good standing, must have paid all local, regional, and national dues, insurance fees, and their membership be on record with the USPC National Office at the time of the rally. Members, parents, and anyone participating in USPC activities must all abide by the applicable Code of Conduct. Members seeking Championships eligibility must meet the criteria determined by the discipline committee and outlined later in this document. For rally purposes, the member's age as of January 1st shall be the age of record throughout the competition year.

Championships Competitor Age and Certification:

Each discipline/division has minimum age and certification requirements for participation in Championships. Championships competitors must meet the age requirement based on their age on January 1 of the Championships' competition year. They must have competed at the minimum or higher certification level at a standard rally and have achieved the minimum certification level by the closing date of the Championships. Therefore, any autumn standard rallies should base their division entry status on the competitor's age for the following year and take into account planned advancements in certification level.

District Commissioners (DCs) and Center Administrators (CAs) are responsible for the eligibility of competitors and mounts at all rallies. It is the responsibility of DCs/CAs and club/center primary instructors to see that mounts and riders are entered in rallies at the level corresponding to the combination's abilities, to make all competitors aware of health requirements i.e., Coggins, immunizations and state health certificates with valid dates, and to see that entry forms are complete and submitted to the rally secretary on time. It is also the responsibility of DCs/CAs to see that all Pony Club members in their jurisdiction have access to a copy of the current USPC discipline rulebook, current USPC Horse Management Handbook (HMH), current USPC discipline annual newsletter(s) and any other relevant information from the USPC discipline committees or the organizer of a specific rally where they will be competing.

Article 6—Member in Good Standing

Members are considered in good standing if they are current with all dues and fees owed the registered club/riding center program, and region.

Article 7—Code of Conduct Expectations

Anyone not conforming to the code of conduct is subject to the following action: the officials of the competition may immediately suspend or expel any individual from the competition upon consulting with the discipline ground jury.

DCs, CAs, RSs, rally organizers, officials and judges must be familiar with, and enforce, the Participating Member and Adult Code of Conduct.

Participating Member Code of Conduct

The United States Pony Clubs, Inc. is proud of its reputation for good sportsmanship, horsemanship, teamwork and well-behaved members. The USPC expects appropriate behavior from all members, parents and others participating in any USPC activity. Inappropriate behavior may include, but is not limited to: possession, use or distribution of any illegal drugs or alcohol; profanity, vulgar language or gestures; harassment (i.e., using words or actions that intimidate, threaten or persecute others before, during or following USPC activities); failure to follow rules; cheating; and abusing a mount.

Adult Code of Conduct

The United States Pony Clubs, Inc. is proud of its reputation for good sportsmanship, horsemanship, teamwork and well-behaved members. It expects no less from the parents, guardians, adult family members or others who volunteer for the organization. The USPC expects appropriate behavior when participating in any Pony Club activity. Inappropriate behavior may include, but not be limited to: profanity, vulgar language or gestures; harassment (for example: using words or actions that intimidate, threaten or persecute others before, during or following any Pony Club activity); failure to follow rules; cheating; or abusive behavior.

"I understand that USPC activities operate under the governance of USPC and are subject to all applicable USPC By-laws, Policies, Rules and Regulations. I understand that I have access to these By-laws, Policies, Rules and Regulations and that it is my responsibility to read them. I agree to adhere to these By-laws, Policies, Rules, Regulations and this Code of Conduct."

Article 8—Human Use of and Alcohol & Drugs Policy (Policy 0500)

In the interest in the safety and welfare of all, it is the policy of the Board of Governors, during any Pony Club activities, to prohibit the inappropriate or illegal use of any substance, including but not limited to drugs or alcohol, by anyone participating in any manner. Weapons of any kind are forbidden.

Article 9—Mounts (Policy 0840)

Mounts used at a regional or interregional rally should be the participant's regular USPC mount, and be accustomed to being handled by its rider without adult supervision. A parti-

SECTION I—USPC Rally Uniform Officiation Rules (UOR)

participant may use a mount other than the regular mount only with the advance permission of the DC/CA and RS.

Per USPC Policy suitable mounts are defined as follows:

1. Stallions are not considered suitable mounts.
2. Mounts must be serviceably sound, in good overall health and in condition for the activity in question.
3. Mounts must be appropriate for the certification level of the rider and must be at a level of training to participate safely in the activity.
4. Except as noted below, mounts must be at least five (5) years of age in order to participate in USPC competitive, instructional, and recreational programs and activities. In establishing the age of mounts, the first year is considered to be January 1 following the date of foaling.
5. Members holding a riding certification of C-1 and above may participate in all USPC activities on an appropriate mount at least four (4) years of age (See above). A mount must be excused from any activity if in the opinion of the instructor, examiner, or appropriate authority, it is unsafe either to its rider or to other riders or mounts.

Ownership of a mount is not a prerequisite for membership in USPC. The responsibility for obtaining a suitable mount for mounted activities rests with the parents or guardians of the individual member.

Article 10—Substitution of Mounts

For all mounted rallies (except Tetrathlon) mount and rider become eligible for Championships as a team. Therefore, a competitor must enter Championships only on the mount they earned eligibility on. In extraordinary circumstances, after becoming eligible for Championships, a substitute mount may be requested utilizing the appropriate form, by the RS and must be approved by the applicable discipline chair and the Vice President of Activities.

Any substituted entry must meet the same mount and eligibility requirements as the original entry.

No mount substitution may be made once a competition has commenced. Refer to the Mount Substitution online application found on the Championships Information page of the USPC website.

Article 11—Sharing of Mounts

In some disciplines and in some competitions, the sharing of mounts may be allowed. At regional rallies, the rally organizer in consultation with the RS may allow for the sharing of mounts by competitors. For Championships, requests for shared mounts must be submitted to the appropriate discipline chair, and VPA utilizing the Mount Substitution online application found on the Championships Information page of the USPC website. Each request will be reviewed on a case-by-case basis, for approval or denial. Determination of shared

mounts must take into consideration the discipline, competition schedule, and suitability of mount. The welfare of the mount will be the highest priority in this situation and all competitors must agree that if the horse management, judges, technical delegate/steward, or organizers onsite feel that the health of the mount is in jeopardy at any time that they may be removed from the rest of the riding portion of the competition.

Article 12—Veterinary Care and Medications (Policy 0860 and 0860.P1)

Per USPC Policy 0860 and 0860.P1. DCs/CAs, RSs, rally organizers, officials and judges must be familiar with and enforce this policy. Parents and competitors must also be familiar with and abide by this policy. Failure to observe this policy will result in disqualification.

1. All mounts in a USPC sponsored activity shall be serviceably sound and healthy. Mounts should be free of medication other than dressings for minor wounds or scrapes, unless under treatment by a veterinarian. Medications and supplements may not be used to provide an unfair advantage over other competitors or to allow an unfit mount to be used.
2. Medication is defined as any substance that is not water, salt, electrolytes, or a supplement and is not considered a normal foodstuff. It is administered either orally, via stomach tube, by application to an external surface, or by injection.
3. Any mount under treatment by a veterinarian for a condition requiring administration of a medication while at a Pony Club activity or competition shall have a veterinarian's certificate stating the diagnosis, medication, dosage and method of administration.
4. Supplements that are administered to any mount at a Pony Club activity or competition must be recorded on the mount's feed chart and stall card.
5. Medications or supplements may only be administered by the owner of the mount, or by a person designated by the owner of the mount.
6. If, during the course of an activity, it becomes necessary to administer a tranquilizer, stimulant, or depressant (e.g., for suturing) the mount may not be used while under the influence of the medication.
7. Competitors at a rally shall be governed by the procedures on the use of equine medications and supplements described in the Horse Management Handbook.

For any competitions recognized by USEF, or in states that require it, mounts may be drug tested.

Article 13—Cruelty to and Abuse of a Mount

Cruelty to or the abuse of a mount present on the grounds of any competition is forbidden and renders the offender sub-

SECTION I—USPC Rally Uniform Officiation Rules (UOR)

ject to penalty. The organizing committee must bar violators from further participation for the remainder of the competition.

Any action(s) against a mount by a competitor or other person, which are deemed excessive by a judge, steward, technical delegate or competition veterinarian, in the competition ring or anywhere on the competition grounds may be punished by official warning, elimination, or other sanctions which may be deemed appropriate by the organizing committee. Such action(s) may include, but are not limited to excessive use of the whip or spurs.

USPC, judges, stewards, or TDs may appoint a veterinarian to inspect any animal on competition grounds or entered to compete. Refusal to submit an animal for examination by an authorized veterinarian after due notification shall constitute a violation.

The following are included under the words cruelty and abuse but are not limited thereto:

1. Abuse. Any act or series of actions that, in the opinion of a judge, TD, steward, member of the discipline ground jury or other rally official can clearly and without doubt be defined as abuse of mounts shall be penalized by disqualification. Such acts include, but are not limited to:
 - Riding an exhausted mount.
 - Excessive pressing of a tired mount.
 - Excessive use of whip and/or spurs, and/or bit.
 - Striking a mount in front of the shoulder.
 - Riding an obviously lame mount.
2. Rapping. All rapping (poling) is forbidden.
3. Whip. The use of the whip must be for a good reason, at an appropriate time, in the right place, and with appropriate severity.
 - Reason—The whip must only be used either as an aid to encourage the mount forward, or as a reprimand. It must never be used to vent a rider's temper. Such use is always excessive.
 - Time—As an aid, the only appropriate time is when a mount is reluctant to go forward under normal aids of the seat and legs. As a reprimand, the only appropriate time is immediately after a mount has been disobedient, e.g., napping or refusing. The whip should not be used after elimination. The whip should not be used after a mount has jumped the last fence on a course or completed the last obstacle.
 - Place—As an aid to go forward, the whip may be used down the shoulder or behind the rider's leg. As a reprimand, it must only be used behind the rider's leg. It must never be used overhand, e.g., a whip in the right

hand being used on the left flank. The use of a whip on a mount's head, neck, etc., is always excessive use.

- Severity—As a reprimand only, a mount may be hit hard. However, it should never be hit more than two times for any one incident. If a mount is marked by the whip, e.g., the skin is broken, its use is excessive.
4. End of the Reins (Western Trail only) - The use of the end of the reins must be for a good reason, at an appropriate time, in the right place, and with appropriate severity.
 - Reason—The end of the reins must only be used either as an aid to encourage the mount forward, or as a reprimand. It must never be used to vent a rider's temper. Such use is always excessive.
 - Time—As an aid, the only appropriate time is when a mount is reluctant to go forward under normal aids of the seat and legs. As a reprimand, the only appropriate time is immediately after a mount has been disobedient, e.g., napping or refusing. The end of the reins should not be used after elimination.
 - Place—As an aid to go forward, the end of the reins may be used down the shoulder or behind the rider's leg. As a reprimand, it must only be used behind the rider's leg. It must never be used overhand, e.g., the end of the reins in the right hand being used on the left flank. The use of the end of the reins on a mount's head, neck, etc., is always excessive use.
 - Severity—As a reprimand only, a mount may be hit hard. However, it should never be hit more than two times for any one incident. If a mount is marked by the end of the reins, e.g., the skin is broken, its use is excessive.
 5. Spurs—Spurs must not be used to reprimand a mount. Such use is always excessive, as is any use that results in a mount's skin being broken.
 6. Bit—The bit must never be used to reprimand a mount. Any such use is always excessive.
 7. Reporting—Officials must report such actions as soon as possible to the discipline ground jury, supported where possible by statements from witnesses.
 - Discipline ground jury—if such actions are reported, the discipline ground jury shall decide if there is a case to be answered. If an individual member of the discipline ground jury observes such actions, they are obliged to disqualify the competitor forthwith on their own authority. There is no appeal against a discipline ground jury's decision in a case of abuse.

Article 14—Dangerous Riding

- Any competitor who rides in such a way as to constitute a hazard to the safety or wellbeing of the competitor, mount, other competitors, their mounts, spectators, or others will be penalized accordingly.

SECTION I—USPC Rally Uniform Officiation Rules (UOR)

- Any act or series of actions that in the opinion of the judge, TD, steward, member of the discipline ground jury can be defined as dangerous riding shall be penalized at the discretion of the discipline ground jury.
- If such actions are reported, the discipline ground jury shall decide if there is a case to be answered. There is no appeal against a discipline ground jury decision.

Article 15—Safety (Policy 0800)

USPC is committed to safety while recognizing that equestrian activities are inherently dangerous. The USPC Safety Handbook is an excellent resource for making safety a priority at all rallies and Pony Club functions. This dedication to safety extends to requiring certain equipment be utilized during Pony Club activities and include:

1. Protective Headgear (**Policy 0810**): USPC requires members participating in mounted and some unmounted activities to wear a properly fitted equestrian helmet, securely fastened, containing certification that it meets the criteria established by the following international or national safety bodies: ASTM F1163 (North America), AS/NZ 3838 (Australia and NZ), PAS 015 (UK).
2. Safety Vest/Body Protector (**Policy 0830**): USPC requires members to wear a properly fitted equestrian body protector when jumping cross-country or solid obstacles during any activity sponsored by the USPC, its regions, registered clubs or riding center programs. A member may wear a body protector at their discretion for any mounted activity. USPC recommends wearing a body protector that is ASTM-certified (manufactured in US) or certified to the BETA Level 3 (manufactured in Great Britain).
3. Medical Armbands and Bracelets (**Policy 0820 and 0820P**):
 - USPC requires that members participating in any USPC affiliated mounted or unmounted activity, must wear either a Medical Armband or Medical Bracelet while participating in the activity. The member may choose which one to wear.
 - Medical armbands must include a current completed copy of the individual's USPC or USEA Medical Card. It must be worn on the upper arm. If the member has small arms, they may safety pin the armband to his/her upper sleeve. (Armbands are available for purchase from Shop Pony Club.)
 - Medical bracelets must visibly list these six items on them: name and date of birth, contact information, known allergies, current medications, and existing medical conditions. More information is acceptable, but these six items are required to be on the bracelet
 - All officials on site at the USPC mounted or unmounted activity are encouraged to work with the competitors to remind them of this requirement.

- Any member at a USPC affiliated mounted or unmounted activity* found not wearing either a medical armband or medical bracelet must be removed from the activity until the member conforms to the policy requirements.

* Tetrathlon competitors will not be required to wear them while actually shooting or swimming but must have them visible and next to them for these activities and must wear them at all other times.

4. Unmounted Footwear: When working in the barn or near mounts unmounted footwear must meet all the following criteria:

- Thick-soled , shoes/boots (short or tall)
- Cover the ankle
- In good condition
- Made of leather or synthetic materials
- Entirely closed
- Securely fastened
- Well-fitted to foot
- Sturdy construction (e.g., Ugg-type boots do not meet this requirement)

Examples: paddock/jodphur boots, rubber riding boots, rain boots/wellies, western boots.

5. Smoking: In the interest of barn safety, it is strictly forbidden for anyone to smoke in or around barn and stable areas.

Article 16—Heat Related Information

Heat Illness (Policy 0900): USPC requires all Pony Club volunteers in a leadership position within Pony Club and especially anyone involved directly with mounted or unmounted lessons or activities to complete the Centers for Disease Control and Prevention (CDC) heat illness training module.

At all USPC activities, rally officials must consider the:

- Temperature and humidity using the "Heat Index Chart" (Appendix II).
- Time of day and season of activity.
- Level of exertion necessary for participation in the activity.

The Heat Index (HI) or "Apparent Temperature" is the temperature the body feels when heat and humidity are combined. This reduces the amount of evaporation of sweat from the body and outdoor exercise becomes dangerous even for those in good shape. Please refer to Appendix II.

Steps to prevent heat related illness include:

- Providing unlimited cool water for consumption in ALL areas, especially riding areas.
- Make water breaks mandatory.
- Do not depend on thirst as an indicator of the need for water.

SECTION I—USPC Rally Uniform Officiation Rules (UOR)

- Avoid the hottest part of the day if this is an option.
- Consider shortening the length/level or exertion of the activity.

During rallies, the discipline ground jury (overall ground jury at Championships) is responsible for monitoring the Heat Index and taking appropriate action as necessary. Those actions could include, but are not limited to:

- Waiving of coats/jackets
- Banning of coats/jackets
- Altering of schedule

Any official can and should bring a potentially dangerous heat situation to the attention of the president of the ground jury. If coats/jackets are waived or banned the following processes should be followed.

Waived Coats/Jackets

When the temperature and humidity are recorded in the danger zone, removal of coats during warm up is mandatory.

If the rider wants to put their coat/jacket on for their competition round, then they may leave their neckwear and helmet cover on during warm up.

If the rider does not want to put their coat/jacket on for their competition round, then they must remove all neckwear and their helmet cover during warm up.

Additional Information

- When coats are waived, the competitors must be turned out per Competition Attire (including coats/jackets) unless they choose to compete wearing Basic Riding Attire.
- Riders must wear a collared shirt with long or short sleeves if they are not wearing a jacket.
- T-Shirts are not permitted.

Competitors must also remove neckwear and helmet covers on vented helmets if they do not wish to wear their jackets for their competitive ride.

Banned Coats/Jackets

When temperature and humidity are recorded in the danger zone and based on the decision of the discipline ground jury (overall ground jury at Championships) coats/jackets may be banned for the safety of competitors. If coats/jackets are banned then competitors must remove coats/jackets, neckwear and helmet covers for turnout inspections, warm up and for competition rounds.

Heat Illness Return To Play

A member believed by a leader, coach, parent or official of a USPC unmounted or mounted activity or competition to be suffering from heat illness shall be removed from play at that time and given appropriate treatment before being allowed to return to play.

Article 17—Concussion and Return to Play

Concussion (Policy 0900): USPC requires all Pony Club volunteers in a leadership position within Pony Club and especially anyone involved directly with mounted or unmounted lessons or activities to complete the concussion training module.

A member believed by a leader, coach, parent or official to have sustained a concussion during a USPC unmounted or mounted activity must be referred to medical personnel. Medical personnel in conjunction with rally officials and organizers will determine if a written release is required for the member to return to the competition.

Article 18—Unauthorized Assistance and Permitted Assistance in all Phases

1. Unauthorized Assistance: Unauthorized assistance is help and/or assistance during the competition from anyone other than other competitors, HMJs, and rally officials. Unauthorized assistance can occur in person or through the use of electronic communication, unless allowed by the specific discipline rulebook (e.g., coaches in certain situations)
2. If, in the opinion of a member of the ground jury, unauthorized assistance has been received by a competitor, that competitor may be eliminated from that phase of the rally, or in extreme cases, disqualified from the entire competition. If there is any question, the discipline ground jury makes the final decision. There is no appeal.
3. Permitted Assistance:
 - Adults may aid in the unloading of mounts and carrying of heavy gear into the stable area upon arrival, after which non-competitors must immediately leave the area.
 - After a fall of a competitor or competitor dismounts, they may be assisted to catch their mount*, to adjust their saddlery, to remount, or to be handed any part of their saddlery or equipment, including whip, while they are dismounted or after they have remounted. Helmets must be replaced, and retention harnesses refastened before riders may remount.
 - * Exception for loose mounts in Games only: In Games, a loose mount may be caught by any competitor or official already in the arena when the loose mount is behind Lines A and C. However, only the mount's rider may enter the playing area to catch it.
 - A competitor may receive clarification of jumping penalties from an obstacle judge, e.g., after jumping a flag at a corner, the judge may clarify whether it was a run-out or not.
 - If bodily harm to mount and/or rider is imminent, assistance from anyone (Official or otherwise), without concern for penalties, is expected. Time permitting, the situa-

SECTION I—USPC Rally Uniform Officiation Rules (UOR)

tion should be brought to the attention of an official. If immediate intervention is necessary, then an official will be notified as soon as possible concerning the situation.

- If a mount is ill or injured, the owner/agent of the mount will be called in to discuss care.

Article 19—Excused

1. Jumping disciplines may call this a “Technical Elimination”
2. To grant permission to, or request that a competitor leave the phase/round/game due to circumstances outside of the competitor’s control (e.g., illness of rider, illness or lameness of mount)
3. Decided by
 - Inspection panel at horse inspection
 - Judge
 - Discipline ground jury
4. May not ride; therefore, will not receive any riding score during the Excuse, but
 - May request a lameness recheck
 - Rider may request to compete in following phases/rounds/games after if illness passes.
 - Both the mount and rider shall stay on rally grounds (unless the mount is transported for medical reasons) and continue to participate with the team and continue to be scored in horse management.
 - If ill, mount will be moved to another area, if possible.

Article 20—Elimination

- Elimination means to exclude a competitor or mount, for cause, from judging consideration in a class/phase. Competitor not scored in a class due to a mistake (e.g., use of illegal equipment, violation of the rules of phase/rounds/ games.)
- After elimination, the discipline ground jury in consultation with the organizer, may allow participation in subsequent phases/rounds/games.
- Determined by judge or discipline ground jury.
- Refer to scoring of penalties for additional discipline specific reasons for elimination.

Article 21—Disqualification

Disqualification is a punishment for misconduct arising from a deliberate attempt to contravene the rules and regulations of USPC applied at the discretion of the discipline ground jury. Any disqualified competitor and their mount may not take further part in the competition including in horse management.

Reasons for disqualification include, but are not limited to:

- cruelty (Article 13);
- abusive or unsportsmanlike conduct;

- obscene or inappropriate language;
- the use of drugs (other than those prescribed by a physician), alcohol, or tobacco (Article 8);
- rude and disruptive behavior;
- cheating;
- rough or dangerous riding;
- knowingly riding a lame, sick, or exhausted mount;
- misuse of equine medications (Article 12);

If such actions are reported, the discipline ground jury shall decide if there is a case to be answered. When considering the disqualification of a competitor, the discipline ground jury may decide to give a Yellow (Warning) Card in lieu of disqualifying a competitor. If a Yellow Card is assigned to a competitor, it may or may not include penalty points not to exceed a 50% impact on the associated phase score if related to a single phase, or a 50% impact on the overall score. There is no appeal against a discipline ground jury decision on issuing a Yellow Card or disqualifying a competitor.

Refer to Section V for additional discipline specific reasons for disqualification and scoring.

SECTION II: General Regulations

Chapter 1—Team Composition

Article 22—Team Formation

Regional Rallies:

The district commissioner (DC) or center administrator (CA) of local clubs/centers are responsible for club/center team formation at regional rallies. A team made up of members from one local club/center remains the ideal and is always the goal. Scramble teams made up of members from multiple clubs/centers are permitted only if a region cannot field a team from within the region. The DCs/CAs of the clubs/centers involved may assist the rally organizer in forming scramble teams. Regional supervisors (RSs) may have final determination. The addition of a fourth or fifth rider to complete a team may be made only if recommended by the RSs of regions involved to the USPC Games Committee Chair.

A region (or even an individual club/center) should make every effort to field an intact team that remains intact through its formation, its regional rally, and through Championships. This team should be chosen with the minimal requirement that all of its rider/mount combinations are safe to compete at Championships. Although there is a natural desire to field a highly competitive team, the maintenance of the integrity of the regional team takes precedence over its competitiveness if the latter means that the regional integrity of the team is lost.

Championships:

A properly formed team, consisting of the same rider/mount combinations which properly became eligible at its standard rally and remains intact, will represent its region at Championships. The rider must ride the same mount that they rode at the standard rally to be considered a rider/mount combination.

Should the entire eligible team that completed the standard rally not be able to remain intact following that rally for Championships, the RS is empowered to complete the team from within their region. The substitute rider/mount combinations should all have competed at the same standard rally. The RS should follow the guidelines set forth in Appendix VIII, Algorithm for Formation of Games Teams. The RS is encouraged in all instances to make every effort to complete their region's team from within their own region. The fundamental minimal riding qualification is that a Pony Club member should be deemed to be able to compete safely within the division that they will be competing in at Championships.

If a region is unable to complete a team from amongst players from within its own borders, the RS should find additional eligible competitors again following the process outlined in Appendix VIII, Algorithm for Formation of Games Teams. This should preferably be a geographically adjacent region. A region should furnish a minimum of three rider/mount combinations from within its own region in order for the team to represent that same region. If a region has only

one or two players who wish to compete at Championships, they must be added to a team from another region that has the minimum number of three.

Regional supervisors who have individual players who have properly earned eligibility for Championships, and whose region is unable to field a team for Championships, are also encouraged to make this player known to the USPC Games Chair. The same is true of regional supervisors who have incomplete teams and who are hoping to complete their three- or four-person team from additional players outside of the region. Although the RS may contact a neighboring RS to discuss completing a team, the RS may also (or alternatively) ask the Games Chair to help in the completion of the team, as the Games Chair will be the repository of those additional players and teams who are looking to complete their teams.

When the substitution rule is invoked its tenants should be followed. Should a team desire to add additional players under the substitution rule, the DC/CA must approve and submit the request to the RS. If the RS approves, the RS must submit their request to the USPC Games Committee Chair for approval by both the Chair as well as the VPA.

Article 23—Team Configuration

Teams shall normally consist of 4 or 5 riding members. One member of the team will be designated as team captain. If competition entry numbers don't allow for 4-5 rider teams, pairs competition can also be allowed at the discretion of the rally organizer and regional supervisor (or VPA at Championships).

Article 24—Team Captains

Each team entered in the competition shall have one member designated as team captain who shall act as spokesperson for the team. Only the team captain may lodge a protest on behalf of any team member (see Article 53).

The team captain is responsible for all communications between the team and rally officials. The team captain is the official spokesperson for the team. In the event of an inquiry, protest or appeal, the captain represents the team. The competitor involved should accompany the captain. It is the responsibility of team captains to ensure that their team members follow all rules and regulations of the competition and to transmit to them any changes or additional instructions provided by rally officials. Any withdrawal of a team member must be reported to the technical delegate.

The team captain shall have full responsibility of directing the team's activities, arriving at the arena on time, sequence, seeing to it that the last rider is wearing the white hatband or cover, overseeing and correcting safety and equipment check procedures.

Teams losing a team captain to illness must designate another team member to take over the responsibilities of captain. If the original captain returns, they will resume the responsibilities of captain.

SECTION II: General Regulations

Article 25—Mount Specifications

1. All mounts entered in USPC Games rally must meet the requirements outlined in Article 9. In addition, Games has the following additional mount parameters.
 - The judging committee shall disqualify any mount that, because of its appearance or the sound it makes, causes other mounts to “spook,” thereby creating a hazard for other competitors, from further competition.
 - Mounts must be familiar with the games being played.
 - The judging committee shall disqualify any mount that is, in its opinion, lame, unruly or otherwise unsuitable for competition. In this case the judging committee’s decision is final and may not be challenged.
2. All rider/mount combinations must meet the following weight parameters. The rider’s weight will be no more than 18% of the mount’s approximate weight. A mount/rider weight table is available in Appendix IX for reference.

Calculation

- $(\text{Mount heartgirth measurement in inches squared} \times \text{mount length in inches}) / 330 = \text{Approximate mount weight in lbs.}$
- $\text{Approximate mount weight in lbs.} \times 18\% = \text{Maximum rider weight in lbs. dressed and ready to ride.}$

Example

- $(65 \text{ inch heartgirth}^2 \times 55 \text{ inch length}) / 330 = 704 \text{ lb approximate mount weight}$
- $704 \text{ lb mount} \times 18\% = 127 \text{ lbs. maximum rider weight}$

Article 26—Chaperones/Emergency Contacts

All competitors below the age of majority must have an official chaperone, 21 years of age or older, listed with rally organizers. All competitors above the age of majority must have an emergency contact, who is available during the competition, listed with the rally organizers. Please review the following criteria for chaperones and emergency contacts.

1. Chaperones:

- Any team with a competitor under the age of majority must have an official chaperone, 21 years of age or older, designated for the competition.
- The chaperone will act as the contact person for that team and must always be on the rally grounds during competition hours.
- Several individuals may share one team’s chaperone duties, but only one name will be listed as the official chaperone. All persons sharing this duty should be made aware of this name and answer to it.
- The chaperone should serve as a volunteer for the competition but may not assume coaching duties.
- Anyone serving as team chaperone must understand and agree to the duties outlined in Appendix III.

2. Emergency Contacts:

- Any competitor above the age of majority must submit a completed Emergency Contact Form (Appendix III) with their entry.
- Those listed as an emergency contact must be available by phone during the competition.

Article 27—Coaches and Coaching

Games coaches are allowed, but not mandatory for all rallies. There may be one or more coaches (may not also serve as chaperone). The presence of a coach at Games rally is to promote safety, good sportsmanship and good horsemanship in the warm-up area and the competition ring. Coaches are expected to help any Pony Club competitor who asks for assistance or whose coach is not present in the warm up area.

Competitors in a rally may also coach other competitors, providing they meet the following criteria:

- Must be 18 years of age as of January 1st of the competition year.
- No scheduling changes will be made to accommodate the coaches/competitors ride times.
- Competitor’s responsibilities and mount’s care always takes precedence over coaching duties.

Games Coaches:

- Must read, understand, sign and return a Coaches Form with the team entry (Appendix VI).
- Must know the USPC Games rules, especially regarding unauthorized assistance; see Article 18. Access to the team is limited and they may not enter the stable area except during authorized visiting times.
- May not approach a judge during the competition. All questions must be directed to the technical delegate.
- May only be in the holding area either outside or along the fences surrounding the playing field.
- Are NOT allowed on the playing field and may not coach once the team has entered the arena/playing field.
- Teams will be penalized with zero points for games in which more than one coach or chaperone in the holding area.
- At Championship competitions, coaches must attend the opening competitor briefing, and the coaches briefing.

SECTION II: General Regulations

Chapter 2—Competition Levels and Divisions

Article 28—Competition Levels

At regional rallies a rider may ride at any level offered, in which they feel their mount would be able to perform. Below are the most commonly offered levels at Games rally:

- **Walk Trot**—This regional-only division is for riders who are beginning their development of games skills and knowledge. They are forming necessary skills such as dismounting and mounting quickly, balance/leaning for drops and pickups, steering/control, and proper hand-offs. It is at the discretion of the rally organizer and/or regional supervisor what kind of assistance (leadline, helpers, etc.) that the teams in this division may use at rally and if there are any penalties for intentionally cantering.
- **Intermediate**—This division is for riders who have developed basic games skills and can independently complete races. Participants should be beginning to develop skills such as dismounting/mounting at increased speed or vaulting, hand-offs, quick corrections, and put downs/pickups with increased speed and accuracy. Riders who have games experience but are not comfortable with higher speeds, could participate in the intermediate division, to develop confidence.
- **Open**—This division is for riders who have experience playing mounted games. Typical Open participants may be able to vault, perform most or all game tasks at speed with accuracy, and perform accurate/quick hand-offs and corrections. Participants must perform all games safely and with control, even at speed. This is the highest level of games competition.

Note: Members, coaches, DCs, and parents should keep these descriptions in mind when forming USPC Games teams. Variations may be necessary due to numbers, availability, and opportunities, however the member's safety, learning, and success is most important.

Article 29—Competition Divisions

Competition divisions differ from competition levels in that competitors may be separated into divisions based on age and/or other parameters. A competitor's age is determined by their age as of January 1 on the year of competition. See Article 5 for more details on age minimums.

- Youth Division—Up to 14 **and including** years of age
- Junior Division—15-17 years of age
- Senior Division—18 years of age and above

Note: Rally divisions can be combined based on entry numbers and approval of the organizer and regional supervisor. Youth competitors can always compete up one division to fill out a Junior team and Junior competitors can always compete up one division as a Senior to fill out a team. Juniors can never

compete down into the Youth division and Senior competitors can never compete down in a Junior division. Before combining Junior and Senior aged competitors on the same team, rally organizers must get the approval of the Junior competitor and their parent/legal guardian (Appendix IV).

If a competitor competes at a higher competition level (e.g. Intermediate competitor rides in the Open competition level), that competitor may not again compete in the Intermediate competition level until the following calendar year. If a competitor competes in an older age division (e.g. Youth rider competes as a Junior), that competitor can again compete in the correct age division in the same year.

Article 30—Championships Divisions—Minimum Age and Certifications

Competitors seeking Championships eligibility must meet the age parameters and minimum certifications for the offered Championships Divisions. There are no age and no certification exceptions to the below requirements. See Article 5 for more details on age and certification minimums.

Modified Youth Intermediate	D-2 DR/EV/Flat/HSE	10-14
Youth Intermediate	C-1 DR/EV/Flat/HSE	12-14
Youth Open	C-1 DR/EV/Flat/HSE	12-14
Modified Junior Intermediate	D-2 DR/EV/Flat/HSE	15-17
Junior Intermediate	C-1 DR/EV/Flat/HSE	15-17
Junior Open	C-1 DR/EV/Flat/HSE	15-17
Modified Senior Intermediate	D-2DR/EV/Flat/HSE	18+
Senior Intermediate	C-1 DR/EV/Flat/HSE	18+
Senior Open	C-1 DR/EV/Flat/HSE	18+

Note: Championship divisions may be combined based on entry numbers and approval from Vice President of Activities and the overall organizer.

Article 31—Championships Eligibility Process

Each individual Pony Club member who desires to compete at Championships must compete in a Regional Rally and be judged at the minimum HM level and same competition level in which they intend to compete at Championships. This constitutes the "individual eligibility" of the competitor.

Team formation follows the individual eligibility and teams attempting to earn eligibility for Championships must follow the team formation process outlined in Article 22 of this rulebook.

Members wanting to become eligible for Championships must meet the below division criteria.

Modified Youth Intermediate—Participate in a standard or modified Games rally at the competition level and play a minimum of eight games.

Youth Intermediate—Complete a standard Games rally at the competition level and play a minimum of eight games.

SECTION II: General Regulations

Youth Open—Complete a standard Games rally at the competition level and play a minimum of eight games.

Modified Junior Intermediate—Participate in a standard or modified Games rally at the competition level and play a minimum of eight games.

Junior Intermediate—Complete a standard Games rally at the competition level and play a minimum of eight games.

Junior Open—Complete a standard Games rally at the competition level and play a minimum of eight games.

Modified Senior Intermediate—Participate in a standard or modified Games rally at the competition level and play a minimum of eight games.

Senior Intermediate—Complete a standard Games rally at the competition level and play a minimum of eight games.

Senior Open—Complete a standard Games rally at the competition level and play a minimum of eight games.

- A region which sends its regional team to another region (visiting team) to compete must have its team finish in the top four, and outscore at least one other team, to become eligible for Championships. In this instance, the visiting region's team, having fulfilled these criteria, will be considered the first-place team for their region and thus will be eligible for Championships.

Article 32—Eligibility Requirements for C-3/B/A Certified Members

Certified C-3, B and A members wishing to compete at Championships do not have to participate at a Regional Games rally but must have permission of their RS.

Article 33—Exceptions to Eligibility Requirements for Championships

Exceptions are occasionally granted. There are no exceptions to minimum age and certification requirements. The process for requesting an exception is outlined on the Championships Competition Information page of the USPC website. All requests for exceptions must come from the RS to the appropriate discipline chair using the online application found on the Championships Information Page of the USPC website.

Chapter 3—Presentation of Competitor and Mount

Article 34—Competitor Identification

Identification numbers (pinnies, bridle numbers, etc.) must be worn in a prominent manner on competitors/mounts, as designated by rally officials. Pinnies must be worn at all times in the barn area. Competitor nametags must be worn at all times, except when mounted.

Pinnies: For regional competitions and Championships, each club/center will provide its own pinnies. It is the responsi-

bility of the regional supervisor, or the local organizer if the regional supervisor so delegates, to ensure that the pinnies from the different clubs/centers are clearly distinguishable from each other so as to avoid confusion in the judging of the competition. The only required information on the pinnies shall be a 6" tall number (1-5) in the center of the pinny, both front and back, that indicates the rider's number on the team. Optional information would be the division (W, I, O) on the left shoulder, with the letters being no more than 4" tall.

Article 35—Competitor Attire

Each participant is responsible for organizing their own attire and equipment which must meet all safety requirements outlined in Article 15. Competitors should be neat and clean with inappropriate jewelry not permitted; see Horse Management Handbook for specifications. Participants must wear a medical armband or bracelet as specified in Article 15.3. A Pony Club Pin must be worn at all times unless otherwise stated by rally officials. Felt can be placed behind pins using the below designations:

Certification	Felt Color
A	Royal Blue
H-A	Orange
B	Red
H-HM/H	Purple
H-B	Brown
C-3	White
C+	Pink
C-1 and C-2	Green
D-1 through D-3	Yellow

Depending on the activity, different attire expectations exist. The different situations and attire expectations are listed below.

1. General Barn Attire—Long pants, mid-length or longer shorts or modest length skirts made of khaki, chino or denim materials of any color, with no rips or tears, a shirt with sleeves, and appropriate unmounted footwear (Article 15.4), are examples of appropriate attire for unmounted work in the barn.
2. Horse Inspection (Jog Outs)—Attire must be safe, appropriate, neat and clean. It must include a helmet (meeting USPC Helmet Policy, Article 15.1), and appropriate unmounted footwear (Article 15.4). Workmanlike and discipline appropriate attire including a tucked in collared shirt with pants/skirt/mid-length shorts/riding pants. If the pants/skirt has belt loops, a belt is required. Blue jeans are not acceptable for english discipline Horse Inspection Attire.
3. Turnout Inspection and first round of competition—All competitors must turnout and compete in appropriate competition attire. Any competitors not seeking Cham-

SECTION II: General Regulations

pionships eligibility may turnout and compete in appropriate competition attire or in basic riding attire as detailed below. Attire requirements may be adjusted based on excessive heat as detailed in Article 15. In inclement weather, competitors will be allowed to wear a helmet cover and a transparent or conservative colored raincoat.

4. Competition Attire for Games

Required

Helmet—Any color that meets the USPC Helmet Policy (Article 15.1). White helmets must be marked by colored tape/other marking to distinguish them from the white cover/band.

Hat Band/Cover—Each team must have a white elastic band or helmet cover that is interchangeable for the last rider in the race.

Hair—Hair should be neatly secured (away from the eyes) and may not cover competitor number.

Shirt—Any colored shirt may be worn, with no more than two colors, with a collar, long or short sleeves and tucked into pant.

Pinnies—Team pinnies with 6" tall number (1-5) in the center of the pinny, both front and back, indicating the rider's number on the team.*

* For Regional Competitions and Championships, each club/center will provide its own pinnies. It is the responsibility of the regional supervisor, or the local organizer if the regional supervisor so delegates, to ensure that the pinnies from the different clubs/centers are clearly distinguishable from each other so as to avoid confusion in the judging of the competition. Team pinnies with 6" tall number (1-5) in the center of the pinny, both front and back, indicating the rider's number on the team. Optional information would be the division (W, I, O) on the left shoulder, with the letters being no more than 4" tall.

Pants—Breeches, jodhpurs (with garters and/or pant clips), riding pants or riding tights of any color.

Footwear—Conventional type of riding footwear, that covers the ankles (short or tall) with a heel. Tall boots (dress or field) or jodhpur/paddock boots, black or brown in color with or without a matching full-grain smooth leather half-chap are allowed. Tall socks worn over breeches with jodhpur/paddock boots are allowed.

Permitted

Gloves—Any type/color.

Safety/Protective Vests—Any color.

Not Permitted

Spurs, belt, full chaps and/or suede half-chaps.

5. Basic Riding Attire for Games:

Unrated and D-1

Required

Helmet—Any color meeting USPC Helmet Policy (Article 15.1).

Hair—Hair should be neatly secured (away from the eyes) and may not cover competitor number.

Shirt—Collared shirt with sleeves and tucked in.

Pants—Long pants.

Footwear—Conventional type of riding footwear, that covers the ankles (short or tall) with a heel.

Permitted

Gloves—Any type/color.

Half-chaps—Any type/color.

Safety/Protective Vests—Any color.

D-2 and up

Rider must be in safe, neat, and clean attire.

Required

Helmet—Any color meeting USPC Helmet Policy (Article 15.1).

Hair—Hair should be neatly secured (away from the eyes) and may not cover competitor number.

Shirt—Collared shirt with sleeves and tucked in.

Pants—Breeches, jodhpurs (with garters and/or pant clips) or riding pants.

Footwear—Conventional type of riding footwear, that covers the ankles (short or tall) with a heel.

Permitted

Belt—Any type/color.

Gloves—Any type/color.

Half-chaps—Any type/color.

Safety/Protective Vests—Any color.

Article 36—Bits, Saddlery and Equipment

The following restrictions begin upon arrival on the competition grounds and continue throughout the duration of the rally. Mounts must be neat and clean and turned out with appropriate english tack. All equipment must be properly fitted and consistent with their intended use.

1. Bridles

English bridles (including nosebands/cavessons, as explained below). English hackamores with shanks of no more than 6 inches and bitless bridles are permitted and do not require a noseband.

SECTION II: General Regulations

2. Bits

Permitted

Snaffle: Bits may be made of metal, more than one metal, rubber, or "happy mouth." Snaffles must be smooth and un-jointed, or smooth with no more than two joints. If a full cheek bit is used, bit keepers must also be used.

Kimberwicks: May be used with a smooth mouth only (mullen mouth piece). Kimberwicks with ports if the port is no more than medium. If using a slotted kimberwick, the rein must be fastened to the bit ring, and may not be fastened to either the snaffle or curb hole in the bit ring.

Curb Bits: Pelhams may be used with a straight mouth (mullen mouth piece). With a pelham bit, if a curb chain is used, a lip strap must also be used.

Not Permitted

Pelhams with ports, Jointed pelhams, Jointed kimberwicks
Please see Appendix VII for examples of approved and unapproved bits.

3. Nosebands/Cavessons

Permitted

Any kind of properly fitted plain noseband/cavesson may be worn. Dropped, figure eight, and flash nosebands are permitted, and may only be worn with snaffle bits.

Not Permitted

Dropped, figure eight, and flash nosebands in conjunction with a Kimberwicke or curb bit.

4. Reins

Reins may be either shorter games/roping reins or longer traditional english buckled reins. If the longer reins are used, they may be knotted to shorten the length. If knotted, the reins must be unbuckled at the end so no loop is left to possibly catch and cause injury. No more than one single rein may be used on a bridle. It must be attached either to the snaffle ring or to a converter connecting the snaffle and curb rings. Reins must have a breakaway feature, either leather around the bit or at the buckle (if they have a buckle or "L" studs at the bit). Reins with snap attachment(s) must have a breakaway feature.

Permitted

Shorter games/roping reins

Traditional english buckled reins

Not Permitted

Nylon reins that buckle or snap at the bit which have no leather breakaway feature.

5. Saddles An english saddle with stirrups must be used with a girth that has two buckles at each end. Each buckle must always be fastened to the first and third billets on each side or the first and second billets on each side.

6. Extra Equipment

Permitted

Standing martingales made of leather which must include a rubber keeper to prevent sliding up and down.

Boots or protective wraps may be used.

Not Permitted

Running martingales

Irish martingales

Overchecks* (lines that attach to the bit and run through the browband to the front dees of the saddle which prevent the pony from putting its head down) are prohibited.

*Overchecks can be used in the Walk-Trot Division.

Article 37—Competitor and Horse Inspections

Horses must be well groomed. Manes and tails must not be braided. Horses need not be shod, but their feet are expected to be in good condition and not in need of any attention upon arrival at the rally. The discipline ground jury may exclude unsafe, inappropriate, lame, otherwise unsound or exhausted horses from the competition at any time during the rally.

Examinations of Horse and Rider Required at Games Rally:

1. Horse Inspections (Jog Outs):

Horse inspections are required at standard rallies and Championships and recommended for all rallies. Before the beginning of competition, the horses must be examined for soundness in hand, by an inspection panel. All horses shall be serviceably sound. Should the soundness of a horse be questioned, the matter shall be reported immediately to the TD, who shall request an inspection of the horse by the veterinarian. In the absence of the veterinarian, the judges or TD shall determine the ability of the horse to compete. All decisions by the veterinarian, TD or judges regarding the soundness of a horse and its ability to compete are final.

- It is recommended that the president of the ground jury be present at the initial inspection.
- The discipline ground jury may, at its discretion, at any time, have any horse jog for soundness before the inspection panel.

2. Turnout Inspection:

Approximately 45-60 minutes prior to the first ride of the competition, all competitors will report to their turnout inspection. The rally organizer will designate turnout inspection times. At turnout inspection competitors must wear the appropriate attire for their discipline and present their mount with all the equipment they will wear/use in the first ride of the competition. More details about turnout inspection requirements are listed in the HMM.

SECTION II: General Regulations

Because all the members are on the field of play at the same time:

- Teams will present themselves for turnout inspection as a group prior to the start of their first game. Team members are expected to report to turnout together.
- Late penalty points will be assessed against any rider, not the entire team, arriving late for their appointed time.
- The turnout inspection will be conducted as per the certification level of each competitor.

3. Safety Check:

Safety checks occur before warm-up for each subsequent ride). Failure to present for a safety check prior to a ride is cause for elimination. More details about safety check expectations are listed in the HMH.

SECTION III: Competition

Article 38—Competition Format

USPC Games rallies are competitions where teams compete against each other in both riding and Horse Management competition. The list of games to be played at Championships will be listed in the Annual Newsletter on the rulebooks page of the USPC website.

Article 39—Competition Schedule

The following is a basic schedule for a Games rally.

1. Briefing—Competitors are responsible for knowing all information from all official briefings whether present or absent. At least one representative from each team must be present at every official briefing.
2. Inspection of Horse (formerly jog out)—required at standard rallies and recommended at all rallies. Opportunity to inspect mounts for soundness.
3. Turnout Inspection—Horse Inspection (formerly jog out) — Each team reports at the assigned time and location for Turnout Inspection with their mount. Riders must present for Turnout Inspection in the exact attire and with all the equipment they will wear/use in the first round of the competition.
3. First round of play
4. One or more subsequent rounds of competition may occur on the same or later days. Prior to each additional round of play a complete safety check of each competitor's attire, mount, and equipment must take place.
5. Turnback—Following all riding rounds, there may be an official check (turnback) of the mount, tack and equipment used for that phase.
6. Awards

Chapter 1—Arenas and Judging

Article 40—Arena Specifications

1. The arena shall be enclosed. The fencing should be approximately four feet high. The arena is set up with lanes running lengthwise. The center line (line B) should be equidistant from lines A (the start/finish line) and line C (the changeover line). The lanes should be established with equal spacing, and with sufficient space on either side of the arena to allow safe running of the races for those teams on the outside lanes. A holding line (six yard line) is marked six yards beyond lines A and C (see diagram). During the play of the game only the next rider out may be in front of the six-yard line. All other riders should remain behind the six-yard line in the holding area. A "run out space" that is kept vacant for incoming riders will be a minimum of 18 feet from the border of the arena to the playing field.
 - A. WIDTH: The recommended ring width will depend on the number of lanes being set up. For example, a ring set up to run four lanes will require less width than a ring set up to run six lanes. A lane is defined as the space used to run

a given race (game). A lane shall be an absolute minimum of 25 feet wide. (An ideal arena will allow lanes of up to 30 feet wide.) The distance is measured from one lane of equipment to the next lane of equipment and from the outside lane of equipment to the fence. If there are width constraints, then they should be addressed on the outside lanes and the fences, leaving the minimum 25 feet distance between each lane of equipment to the next lane of equipment. In races using the bending poles, the teams will run lengthwise through the poles. In races not using the bending poles, the poles may be left in place as "lane dividers." If this is done, there should be sufficient distance allowed on the outside lanes to permit safe play of the race for the teams on the outside lanes. If there is not sufficient width to allow for this additional space on the outside lanes of the arena, then the bending poles should be removed for races not using them.

- B. LENGTH: The arena distance from line A to line C may be adjusted to accommodate the space that is required beyond lines A and C. It must be no less than 116 feet and no more than 200 feet. In addition to this length, there must be a six yard area (18 feet) behind both lines A and C for the holding area with 18 feet minimum behind the holding lines (six yard lines) for waiting riders. An additional 18 feet "incoming zone" behind this waiting area will remain vacant during the play of the game to allow for adequate stopping space (see diagram). This gives a total of at least 54 feet beyond both lines A and C. Given these parameters, the total arena length required for a rally must be no less than 224 feet. There are several variables which may be used to accommodate these distances depending on the length of the arena for a given rally:

1. The distance between bending poles may be changed. The maximum recommended distance between poles is 30 feet but the minimum distance of 24 feet may be used. (i.e., Using the shorter distances between the poles would allow for the distance between lines A and C to be decreased.)
2. The distance between the first pole and line A and the last pole and line C may be changed. If there are length constraints, this distance may be a minimum of 10 feet and a maximum of 24 to 30 feet.
3. The waiting area can be shortened, but the incoming zone must be at least 18 feet.
4. The start and finish line will be the same line at one end of the arena, with the changeover line at the other end, (line A is start/finish, line B is the centerline, line C is the changeover line.).

FINAL APPROVAL: The technical delegate shall have the responsibility to make the final determination as to the adequacy and safety of a Games arena prior to the beginning of a rally.

SECTION III: Competition

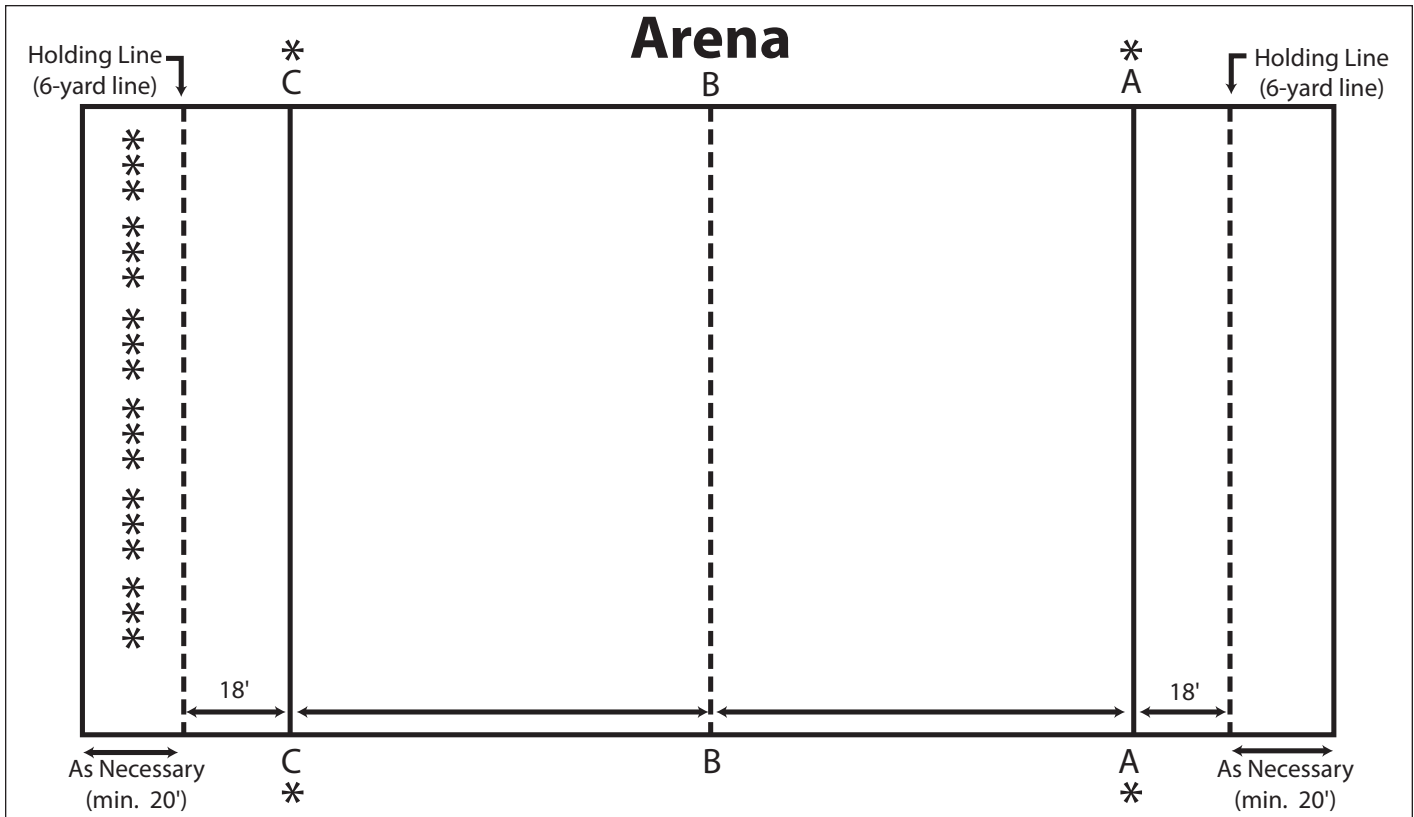

* Line judges required as indicated by single asterisks;

*** Lane judges indicated by triple asterisks. These judges should stand behind the line C collecting area.

Article 41—Warm Up Area

A warm-up area must be provided. The warm-up area does not include any practice equipment and should be near, but not necessarily next to, the competition arena. It does not have to be enclosed. In cases where there is limited space for schooling/warm-up. The number of mounted allowed to warm-up at one time may be restricted by rally organizers.

Article 42—Access to Arena

Once excused from the arena, no member of any team may re-enter the arena for any reason until the next regularly scheduled game. Breach of this rule shall result in disqualification for the race previously run, or disqualification from the competition by the discipline ground jury. A re-entry for a mundane reason (e.g., recovery of a lost stirrup, saddle pad or hat cover) must be approved by the line A judge/starter and be accomplished on foot by one team member without a mount.

Article 43—Execution and Judging of Games

1. Riders must remain mounted at all times while in the playing arena unless the rules for the specific game call for them to be unmounted. If unmounted, they must remount when they have completed their part of the

game and remain mounted until excused and out of the playing arena. All riders not in the start box must stay in the holding area (6 yards behind the starting line and 6 yards from the border of the playing field). They must stay at least 18 feet away from the end border of the field. This “incoming zone” near the end of the field is for incoming riders only and is to remain vacant during the play of the game.

2. The lane judges shall report any infractions to the line C judge, who in turn notifies the overall judges of the infraction at the completion of each game (or heat if run in heats).
3. Upon completion of the game, having checked for any infractions and having conferred with the starter, the overall judge shall announce to all competitors (who are assembled in the arena) the winner and relative standings of all the teams. At this time, the scorer shall record the results on the master score sheet upon approval of the judging committee.
4. The starter or chief overall judge only, at their discretion, may stop a game at any time if they feel that continuance of the game will unreasonably endanger any competitor or mount. If it becomes necessary for the starter or chief overall judge to stop a game, the entire game shall be replayed from the beginning, unless the overall judge determine that sufficient teams have completed the game. However, the team whose actions required the

SECTION III: Competition

stoppage will be eliminated from the game and shall not take part in a replay or receive points for the game.

5. Once excused, competitors must walk from the arena. Failure to remain mounted, remount, remain in place, or walk out of the arena until excused shall result in disqualification.
6. Competitors should always finish the game (other teams may have been eliminated). The overall judge and starter can call a game if it is taking too long.
7. Competitors should always correct mistakes, no matter how long it takes. Should a rider drop an article that they have to carry, hand over, or put into or take out of a container (or place on or take off a bin, post, etc.), they may dismount to pick it up then place it where it has to be while unmounted. The competitor must then remount to continue the race. At a hand-over, either rider may pick up and may hand it over unmounted. Should a rider knock over a container, bin, post, etc., mentioned above, they must immediately set it up again and replace all articles, which should be in or on it, except the one being collected, which need not be replaced. The rider can dismount and do this by hand or remain mounted if they wishes. If the correction is made unmounted, the rider must remount to continue the race. The penalty for infringement is elimination.
8. The next rider to go (or the first rider if #4 is on course) should be watching the rider on the field to see that the game is played correctly and be ready to give directions or advice.
9. In all races in which the riders weave around bending posts, the following will apply: The riders may pass the first post on either side (right or left). Thereafter, they weave alternately to the right and left of successive posts.
10. Teams will determine the order of go will depend on the game.

Chapter 2—Playing of Games

Article 44—Start

The competing teams shall be in position for the start of each game as required by the rules for that game. Only one mount and rider per team will be allowed between the start line and the 6-yard line for the start of a game unless otherwise specified for a specific game. The signal to start will be the drop of a flag. All starts will be standing starts from behind the start line. The starter may order any unruly mount to stand or be held behind the holding-area line (6-yard line) until the flag drops.

The starter will start the race, and all judges will observe the running of the race. After consultation with the assistant line A judge, the starter will report the order of finish and any line A infractions to the overall judges. The line C judge will consult with the assistant for any line C violations, and with

the lane judges for any infractions in their lane, and report the information to the overall judges. The overall judges will contribute their observations, and the judging committee will then make the final determination as to any infraction and placing. The determination by the judging committee is absolutely final and not subject to inquiry, protest or appeal. Disagreements among members of the judging committee will be decided by the chief overall judge. If the judging committee is an even number, the decision of the chief judge shall prevail.

A false start is one in which a mount has started forward motion prior to the dropping of the flag (whether or not it has crossed line A) or, for whatever reason, a team is not prepared to start equally with the other teams. It is the responsibility of the first rider to be alert for the dropping of the flag.

Only the starter can call a false start. No team is allowed more than two false starts per game. A third false start will incur disqualification from just that game. If the starter determines that there is a false start, a whistle will be blown to stop play.

Article 45—Changeover

All four legs of both mounts must be behind the line during a changeover. During a handoff, only the two members involved in the handoff may participate in the action, all others must be behind the 6-yard line. Once an outgoing rider is within the 6-yard area, that rider must take the hand-off and be the next to go. Handoffs may take place behind the 6-yard line. At all handoffs, the outgoing rider must have rein contact with the mount. Except in the case of a fall or similar unforeseen circumstance, the rider must, on penalty of disqualification, maintain a constant rein contact with the mount while in the Games arena. Temporary, accidental loss of rein contact, immediately regained, may not, at the judging committee's discretion, be cause for disqualification.

Article 46—Result of Race

The results of a race will be decided by the order in which the mounts' heads cross the finish line (when ridden) or the riders cross the line (when unmounted). When mounts finish in pairs, it is the head of the second mount that counts. In all mounted races, a rider is not considered to have finished unless the rider has crossed line A or C as appropriate, facing forward, seat in the saddle and one leg on each side of the mount or facing forward with both feet in the stirrups. At the discretion of the overall judge, a game or heat may be terminated if the last team is taking an unusual amount of time to complete the game (e.g., searching for a lost ring or golf ball, or all other teams have finished play several minutes before). If this occurs the team will be eliminated from that game and receive one point.

- The last rider of each team will wear a white hatband or white helmet cover around their hat to designate to the

SECTION III: Competition

judge that their team has completed the game. If a team's helmet cover is light colored, a white helmet cover must be used for the last rider for ease in judging. The penalty for the wrong rider wearing the hat cover or band will be elimination from that particular heat or game.

Article 47—Rotation

1. Teams should be rotated among lanes and heats as equitably as possible, so that no team achieves an advantage by running in a certain lane or with other teams.
2. If there are more teams than lanes for a given competition, then the teams shall be rotated on a random basis amongst each other during the course of the competition. The goal and intention of this rotation is to give each team a reasonable exposure to every other team in the competition during the course of the entire competition. When multiple heats are to be run, the scoring method shall remain the same for each heat.
3. If multiple heats are required, and if the teams do not divide equally, then the scoring system shall be utilized that matches the scores for the heats with the greatest number of teams. For example, if three heats are being run that have 6, 6 and 5 teams in each heat, the first place team shall receive 7 points in all three heats.

Article 48—Tie

When after the last game there is a riding score tie, a tie breaker race will be run to determine placing. This race will be scored, but used only to rate the teams' finishes. This game will have been selected by the organizer in advance and published with the games to be played on the entry form.

If for any reason any game cannot be run, it may either be replaced by the tiebreaker or be declared void at the discretion of the judging committee.

Article 49—Saddlery During Game

The reins must be properly arranged over the mount's neck during any mounted phase of the Games. Reins may be knotted. If in the course of a game the rider is required to lead the mount, it is not required that the reins be put over the mount's head in the conventional leading pattern but may remain over the neck.

Should a stirrup come off during a game, it need not be replaced until the end of the game; the rider's feet do not have to be in the stirrups at all times during mounted phases.

Article 50—Error in Race

In the event that an error is committed (e.g., knocking over a bending pole, missing the bucket, etc.) the rider committing the error must return to correct it. Unless otherwise specifically stated in the rules for a specific game, this correction may be made either mounted or unmounted. If unmounted, the rider must remount to continue the race. Should the last rider commit an error, but crosses the finish line before correcting it, they may return and correct the error, as prescribed, but will not be considered to have finished until they again cross the line.

SECTION III: Competition

Chapter 3—Types of Games

Article 51—Games for 4-5 Rider Team Competition

BALL AND BUCKET RACE

Required Equipment:
 One 5-gallon water bucket
 Five tennis balls

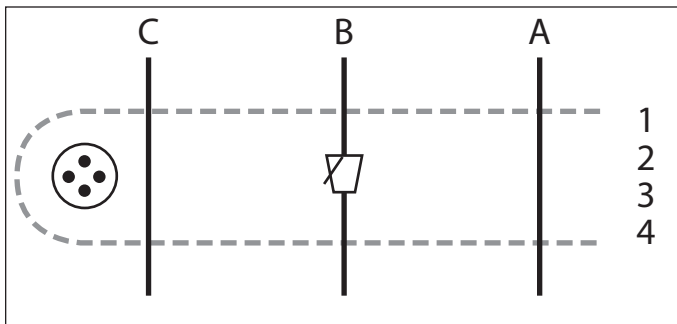

DETAIL: Three yards behind line C there will be four tennis balls, which may be placed within a 24" diameter painted circle for visibility if desired. On line B will be the bucket. On the signal to start rider number one, carrying a ball, will ride to the bucket and drop the ball into it. The rider then continues to the far end to pick up a ball. The rider must dismount to pick up a ball and may dismount at any time after they have successfully dropped the ball into the bucket, but the rider and all four feet of the mount must cross line C (either mounted or unmounted) before returning for the handover regardless of where the ball was picked up. Riders two, three and four complete the event in the same manner with rider number four dropping the last ball into the bucket on their way back (double dunking). If the balls are knocked out of the circle, they need not be placed back in.

BALL AND CONE RACE

Required Equipment:
 Two traffic cones 18" high
 Two tennis balls

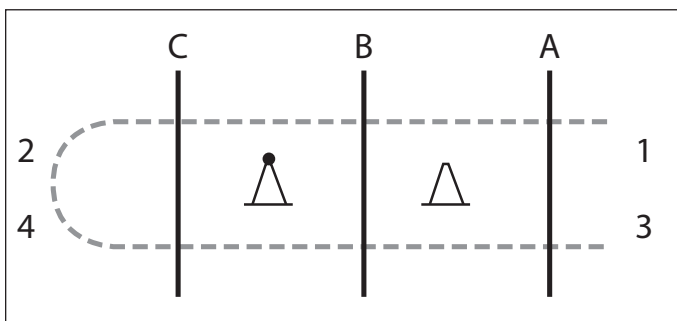

DETAIL: There will be two cones, each one placed 15 yards from lines A and C. A tennis ball will be placed on the cone closest to line C. Riders one and three will be mounted at the start line and riders two and four at the Changeover end. Rider one carries a tennis ball and on the signal to start, rides to the first cone and places their ball on it; they then ride to

the second cone, collects the ball and hands it to rider two. Riders two, three, and four complete the course in the same manner. The winning team is the one whose rider number four is the first over the finish line carrying the ball.

BALL AND RACQUET

Required Equipment:
 Four bending poles, placed 24-30' apart
 One tennis ball
 One tennis racquet

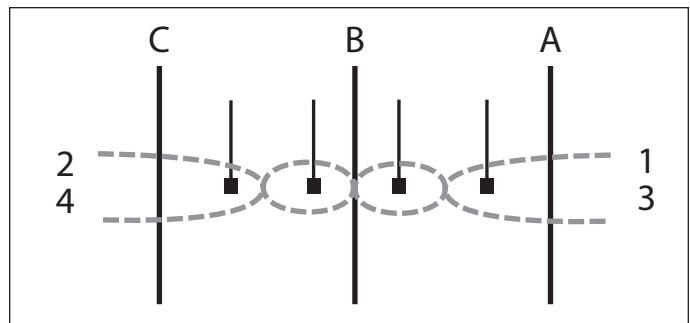

DETAIL: Four bending poles will be placed 24 to 30' apart centered between lines A and C. Riders number one and three will be behind line A; riders two and four will be behind line C.

Rider number one will carry the tennis racquet on which is placed a tennis ball. On the signal to start, rider number one will ride down the line through the bending poles carrying the tennis ball on the racquet. The tennis ball must not be touched by hand, except when being picked up. On arrival at line C, rider number one will hand the racquet and ball to rider number two, the tennis ball still being untouched by a hand. Riders number two, three and four will complete the course in the same manner up and down the arena successively. The winning team will be the one whose rider number four crosses the finish line first with the tennis ball on the racquet.

Should the tennis ball be dropped, the rider must pick it up and resume the course again from the point where the ball was dropped. The ball need not be placed on the racquet until this point is reached. Should the ball and/or racquet be dropped over the handoff line either rider may retrieve the ball, mounted or dismounted and place the ball on the racquet of the next rider to go.

Each racquet will have a colored band around the handle 3" below the head and competitor's hands must be behind this band.

SECTION III: Competition

BALLOON RACE

Required Equipment:

One board, 1" x 8" x 10'

Six round balloons (not elongated)

One lance (wooden or plastic 4' dowel, 1/2"—3/4" in diameter), with 1" brad driven into one end so that no more than 3/8" of the brad remains

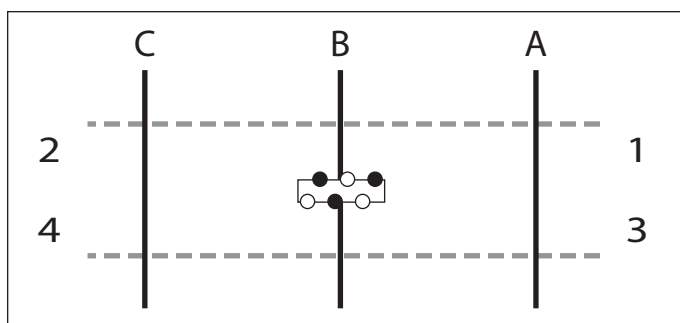

DETAIL: The 8 to 10-foot board with three 1" grooves cut into each side of the board (see diagram) will be centered in line B (Can be the same board used in Stepping Stone Dash). Six round balloons (three on each side) will be inserted into the grooves in the board. Riders number one and three will be at line A and riders two and four will be behind the changeover line. Rider number one, carrying the lance, rides to the balloons, bursts one, rides on to the changeover line and hands the lance to rider number two. Riders two, three and four complete the course in a similar manner, up and down the arena, bursting a balloon, in succession. The winning team will be the team whose rider number four is first over the finish line, mounted and carrying the lance.

Each rider (not the mount) must break a balloon. In the event all of the balloons are burst before the last rider goes, the team will be eliminated from the game.

BENDING RACE

Required Equipment:

Five bending poles, placed 24-30' apart

One baton

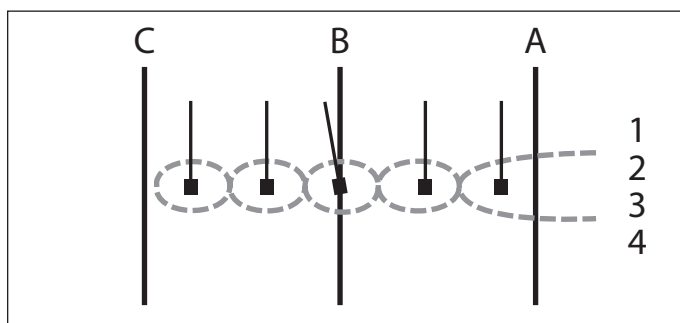

DETAIL: A bending pole is a plastic pole in a metal, plastic, concrete or rubber cone base (total height 4'6"). The baton is 10-12" long, 1" in diameter. Rider number one, carrying the baton, rides across line A, down the line of bending poles, passing them on alternate sides, turns around the last pole and returns in the same manner, crossing line A. Once behind

line A, they hand the baton to rider number two. Riders two, three, and four complete the course in the same manner. The winning team will be the team whose fourth rider crosses the finish line first, mounted and carrying the baton.

BOTTLE RACE

Required Equipment:

Two heavy duty plastic trash bins, or similar, 23"-27" high, approximately 19" in diameter, with plywood circle bolted to bottom. (See Appendix for instructions on how to construct this).

Two 1-liter plastic bottles, 1/2 filled with sand.

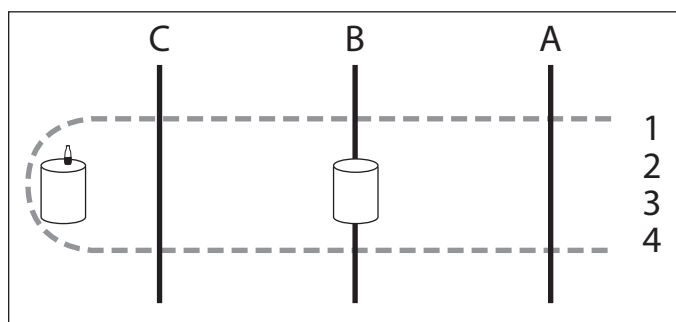

DETAIL: There will be a trash bin as described above placed upside down on the centerline and a similar bin three yards behind the changeover line. On the bin beyond line C will be one plastic bottle. On the signal to start, rider number one, carrying a similar bottle, will ride to the first bin and place the bottle upright on the bin. They will then continue to the far end to pick up the bottle from the bin there and return, crossing line A to handoff to rider number two. Riders two, three, and four complete the course in a similar manner. Each rider in turn places the bottle on the empty bin and collects a bottle from the other bin. Bottles must remain upright on the bins throughout the race. The winning team will be the team whose rider number four crosses the finish line first, mounted, carrying a bottle.

THE CANADIAN RACE

Required Equipment:

Two traffic cones 18" high

Four bending poles, placed 24-30' apart

Four tennis balls

One plastic hockey stick, length approx. 40" (street hockey stick is best)

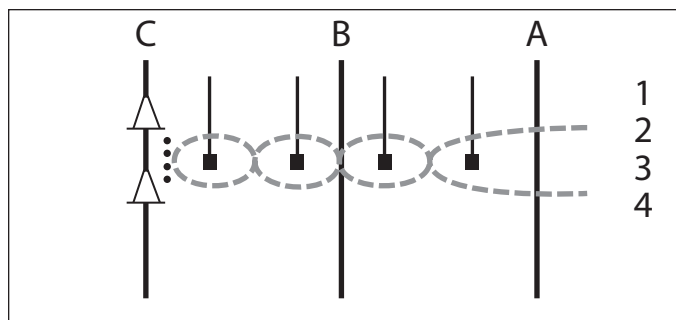

SECTION III: Competition

DETAIL: Four bending poles will be placed 24 to 30' apart centered between lines A and C. Two cones will be placed 6' apart on line C creating the "goal." Four tennis balls spaced 1 foot apart will be placed 3 feet from line C lined up with the goal opening.

On the signal to start, rider number one weaves through the bending poles carrying the hockey stick and hits one ball; the rider must continue to hit the same ball until it goes through the goal posts (cones). Rider one will then return weaving through the bending poles and hand off the hockey stick to rider two. Riders number two, three and four will complete the course in the same manner in succession. The winning team will be the one whose rider four is first over the finish line, mounted and carrying the hockey stick. All four bending poles and the cones must be upright.

In the event that a mount kicks a ball through the goal, that ball must be brought back over the goal line by the rider whose mount kicked it over the goal line. The ball does not have to go back to its original position.

Riders must bend the poles when returning to the start/finish line but the bending pattern need not be a continuation of the weave on the way down.

CARTON RACE

Required Equipment:

- Four bending poles, placed 24-30' apart
- Four plastic or cardboard litter cartons
- One 5-gallon water bucket

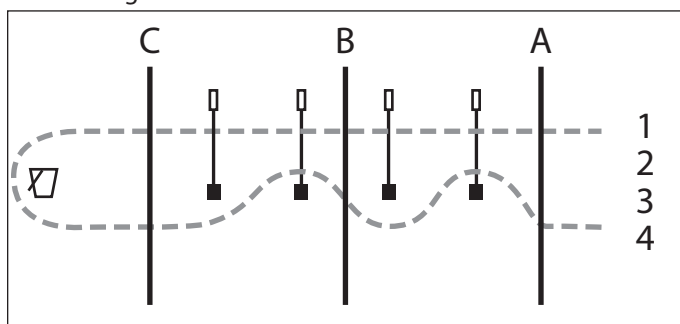

DETAIL: Four bending poles will be placed 24 to 30' apart centered between lines A and C. One carton is placed on top of each pole. The bucket is placed 3 yards beyond the changeover line. Riders number one, two, three and four will be behind line A.

On the signal to start, rider number one collects a carton from any pole, rides to the bucket, drops the carton in the bucket and returns, bending the poles, to the start/finish line. Riders number two, three and four will complete the course in the same manner up and down the arena successively. The winning team will be the one whose rider number four crosses the finish line first with all four cartons in the bucket.

Poles which are knocked over must be reset before proceeding.

EGG AND RACQUET RACE

Required Equipment:

- Three bending poles
- One solid wooden craft store egg
- One tennis racquet

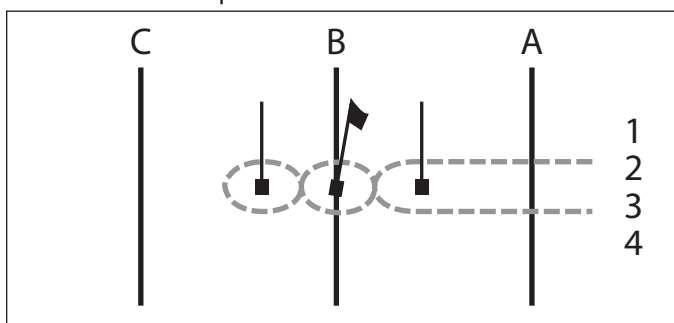

DETAIL: Three bending poles will be put up 24' to 30' apart. Rider number one will carry the tennis racquet on which is placed an egg. On the signal to start, rider number one will ride up and down the line through the bending poles carrying the egg on their racquet. The egg must not be touched by hand, except when being picked up. On arrival at the finish line, rider number one will hand the racquet and egg to rider number two, the egg still being untouched by hand. Riders two, three, and four will complete the course in the same manner up and down the arena successively. The winning team will be the team whose rider number four is first over the finish line carrying the egg on the racquet. Should the egg be dropped, the rider must pick it up and resume the course again from the point where the egg was dropped. The egg need not be placed on the racquet until this point is reached. Should the egg and/or racquet be dropped over the handoff line, either rider may retrieve the egg, mounted or unmounted, and place the egg on the racquet of the next rider to go.

Each racquet will have a colored band around the handle 3" below the head and competitors' hands must be behind this band.

FISHING RACE

Required Equipment:

- One 5 gallon water bucket
- Four wooden fish 1/2" thick, with a small screw eye in the mouth end
- One wooden or plastic 4' dowel, 1/2"—3/4" in diameter, with a cup hook on one end
- One 3/4" diameter 4'-high post with a cross piece with four cup hooks screwed into the bottom side

DETAIL: The bucket containing the four wooden fish will be placed on line B. Rider number five (or a volunteer) will stand 3 yards behind the changeover line holding the 4' post.

On the signal to start, rider number one, carrying the dowel, will ride to the bucket, hook a fish on the end of the dowel and continue to rider number five/volunteer. Rider number five/volunteer unhooks the fish and secures it on one of the

SECTION III: Competition

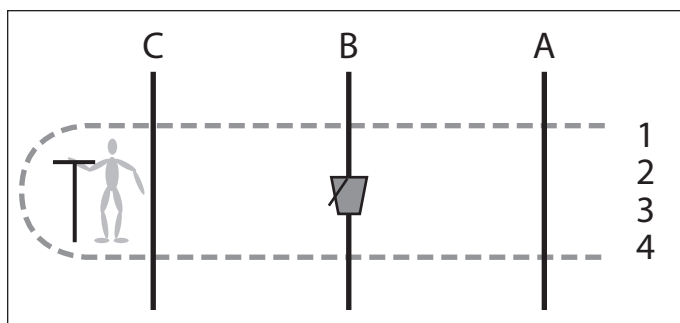

hooks on the post. All 4 feet of the mount must cross and remain behind the line C until rider number five has correctly placed the fish on a hook, then they ride to the start line to handoff the dowel to rider number two. Riders two, three and four complete the race in the same manner. The winning team will be the team whose rider number four crosses the finish line, carrying the dowel and with all four fish on hooks

If a fish is dropped while handing over to the person holding the post, that person may pick it up and put it on the post; it need not be replaced on the rider's dowel. The holder shall signal by raising a hand that the fish is securely hung, so that the judges can determine when the rider may properly return. Failure to so signal, however, shall not carry a penalty.

The rider must hook the fish from the bucket while mounted. If the bucket is knocked over before the fish is hooked, the rider must reset the bucket, replace all the fish and then proceed to hook the fish while mounted.

If the bucket is knocked over after the fish is hooked, the rider must reset the bucket and replace the remaining fish. Any correction may be made mounted or unmounted using the hand or the hook. If the hook is used to correct the error, the rider may remove the fish by hand and replace it by hand after the error is corrected.

FIVE CONE

Required Equipment:

- Five traffic cones, 18" high
- Five tennis balls

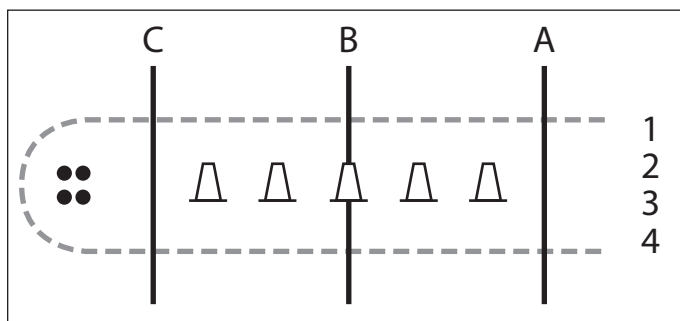

DETAIL: Five cones will be placed 24-30' apart, centered between lines A and C, with the number one cone being closest to line A. Four tennis balls will be placed 3 yards behind line C (within a ring marked on the ground). One ball is given to the first rider.

On the signal to start, rider number one, carrying a ball, rides to cone two and places it on the cone. The rider then continues to the far end, and once all four feet of the mount have crossed the C line, the rider picks up a ball either mounted or unmounted, and then returns to the A line where the ball is passed off to rider two. All remaining riders complete the course in the same manner with rider two placing ball on cone 3, rider 3 placing the ball on cone 4, and rider 4 placing the ball on cone 5, and then placing the last ball on the first cone before crossing the finish line. The winning team will be the team whose rider number four is first over the finish line mounted with all five balls on all five cones.

FIVE-FLAG RACE

Required Equipment:

- Two 18" traffic cones, cut down to leave 4" diameter opening (same as Two Flag cones)
- Five flags, 4' long

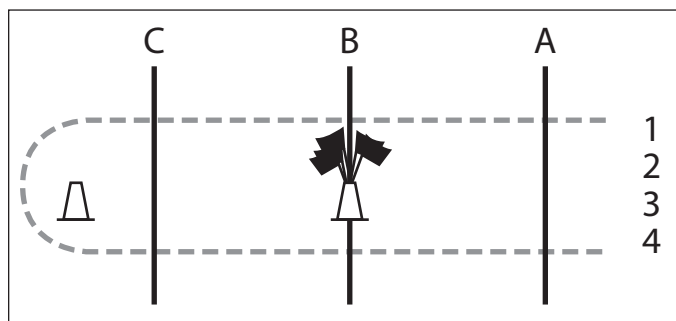

DETAIL: Place one cone 3 yards behind line C. A second cone will be placed on line B with four flags placed in it. One flag is given to the first rider. (A flag consists of the following: 3' wooden dowel, 1/2" diameter, a piece of cloth 6" x 8" attached to one end of each of the dowels.)

On the signal to start, rider number one will ride to the other end of the arena and place the flag they are carrying in the holder there. They will ride back, picking a flag out of the team's holder on line B and hand this flag to rider number two behind the start line. Riders two, three and four will complete the course in the same manner, up and down the arena in succession so that at the end, the team will have placed four flags in the holder at the far end of the arena and rider number four finishes over the start line mounted and carrying the fifth flag. Should any rider take more than one flag from the holder, they must replace the surplus. A flag not in possession of the rider, (e.g., those that have fallen out of the holder), must be picked up and returned to the holder, mounted or unmounted. If the flag is dropped while an attempt has been made to place the flag in the holder while mounted, the flag may then be placed in the holder mounted or unmounted. Holders knocked over must be reset, either mounted or unmounted, by hand or by flag. If a flag should come off the cane, the stick may be used to complete the race. On windy days, rubber bands can be used to keep the flags furled and prevent them from blowing over.

SECTION III: Competition

FIVE MUG RELAY

Required Equipment:

- Five bending poles, placed 24-30' apart
- One heavy duty plastic trash bin, or similar, 23-27" high, approximately 19" in diameter, with plywood circle bolted to bottom.
- Five 12-14 oz. plastic, enamel or stainless mugs with or without handles

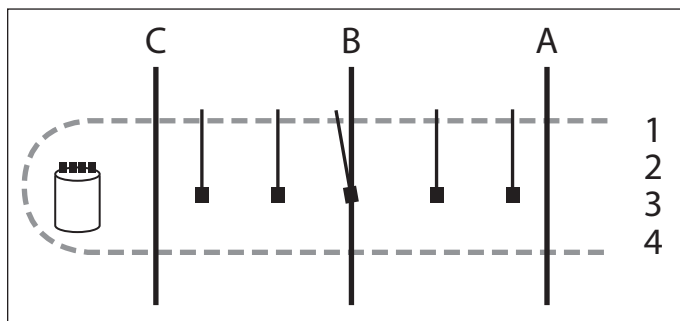

DETAIL: The bending poles will be placed 24 to 30' apart centered on line B. For the purposes of this race, pole #1 will be the pole closest to line A. The trash bin will be placed 3 yards behind the changeover line, in line with the bending poles. Four mugs, placed upside down, will be put on the trash bin; rider number one at the start will carry the fifth mug.

On the signal to start, rider number one will go to one of the team's poles and place the mug, inverted on the top, on any pole other than pole #1. They will then go on to the bin, pick up another mug and return to handoff to rider number two, waiting behind line A. Riders two, three and four will each complete the course in the same manner in succession, with rider #4 placing the last mug, inverted, on pole #1 on the way back to the finish line. The winning team will be the team whose rider number four is first over the finish line, mounted with a mug placed on each of the team's five poles.

Riders ride straight and do not bend through the poles. Any mugs knocked off the bin must always be replaced upside down.

GOLF BALL AND SPOON RACE

Required Equipment:

- Three bending poles, placed 24-30' apart
- One golf ball
- One long-handled spoon (with a 1" strip of brightly colored tape on handle where it meets the bowl)

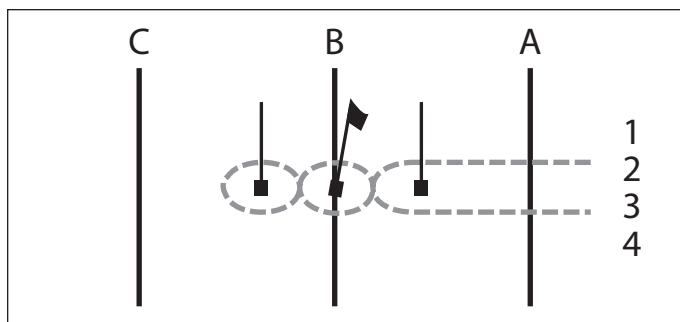

DETAIL: The bending poles will be placed 24' to 30' apart, midway between lines A and C. The first rider of each team will carry the spoon on which the golf ball is placed. On the signal to start, rider number one will cross line A, ride down the line of bending poles passing them on alternate sides, turn around the last pole and return in the same manner, crossing line A. Rider number one will hand the spoon and golf ball to rider number two, the golf ball still being untouched by hand. The second, third and fourth riders will complete the course in the same manner successively. The winning team will be the team whose fourth rider crosses the finish line first, carrying the golf ball on the spoon. The golf ball must not be touched by hand except when being picked up or while mounting.

Should the golf ball be dropped, the rider must pick it up and resume the course again from the point where the golf ball was dropped. The golf ball need not be placed on the spoon until this point is reached.

The spoon may not be held or touched in the area marked by the brightly colored tape except while mounting. If dropped at a handover, the golf ball and/or spoon may be retrieved by either rider, mounted or unmounted, and placed on the spoon of the next rider to go.

HI-LO RACE

Required Equipment:

- Four 18" traffic cones
- Five tennis balls
- One 7' pole with 8" steel ring with net or bag attached

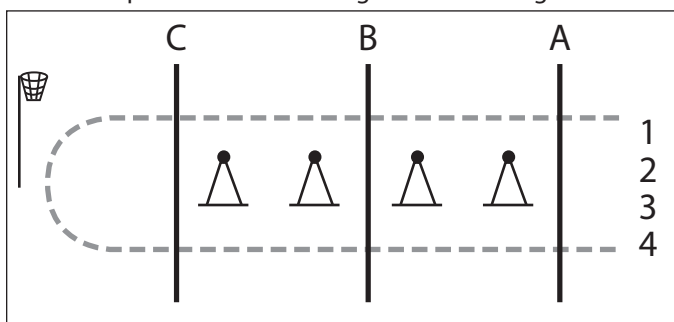

DETAIL: The 18" traffic cones will be 24' to 30' apart; a tennis ball will be placed on the top of each traffic cone. Three yards beyond line C, there will be a pole with an 8" diameter steel ring, 7' from the ground, with a net or bag attached to the ring. Rider number 5 or a volunteer will hold the post.

However, the ball MUST be placed in the net or bag while mounted.

Rider number one will carry a tennis ball and place it in the net or bag and upon returning down the arena, collect a ball from the top of one of the cones (except for cone #1) and pass it to the next rider. Riders two, three and four will complete the course in the same manner, with rider #4 picking up the last ball on cone #1. The winning team will be the team whose fourth rider crosses the finish line first, mounted, carrying a tennis ball.

SECTION III: Competition

HOUSEWIFE'S SCURRY

Required Equipment per team:

One heavy duty plastic trash bin, or similar, 23-27" high, approximately 19" in diameter, with plywood circle bolted to bottom.

One plastic paint bucket

One 5-gallon water bucket

One potato, one apple, one orange, one carrot, one onion (plastic fruit and vegetables may be used)

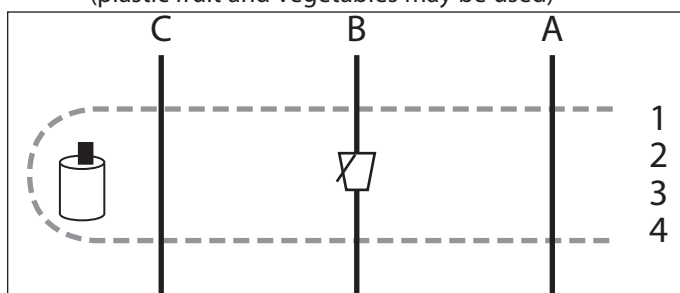

DETAIL: Place the trash bin 3 yards beyond the changeover line. On top of the bin, place the plastic paint bucket containing one apple, one orange, one carrot and one onion. The potato is given to the first rider.

On the signal to start, rider number one crosses the start line carrying a potato, rides to their team's bucket (on line B) and drops the potato in. This rider continues over the changeover line, takes the apple from the team's container, rides over line A for the handoff to rider number two. The second, third and fourth riders of each team, in succession, complete the course in the same manner—rider number two collecting the orange, number three collecting the carrot and number four collecting the onion. The fourth rider will drop the onion into the team's bucket on the way back (double dunk) to the finish line. The winning team will be the team whose fourth rider is across the start/finish line, with nothing left in the hand.

Should a rider collect and drop the wrong article into the bucket and not correct the error, their team will be eliminated.

Should the bucket containing the fruit and vegetables be knocked over but remain on top of the bin, it must be placed upright even if it is empty. This may be done mounted or unmounted.

HULA-HOOP RACE

Required Equipment:

One hula-hoop, at least 28" in diameter

DETAIL: This race is ridden in pairs with the third rider of each team behind the changeover line. A hula-hoop at least 28" in diameter for each team will be placed on the centerline. Riders one and two at the start line will ride to the hoop, rider number one dismounts and goes through the hoop while rider number two holds the mount. Rider number one remounts and the pair rides on to the changeover line where

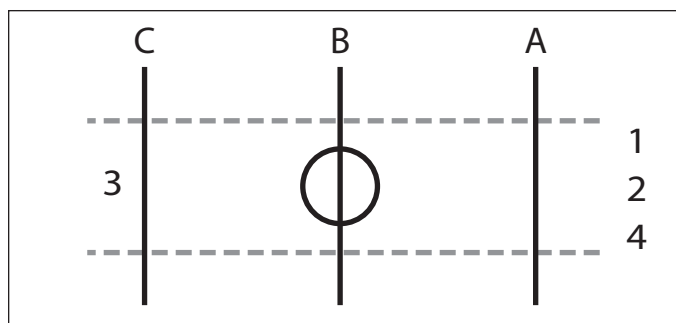

rider number one drops out, rider number two picks up rider number three. Rider number two goes through the hoop while rider number three holds the mount. The pair rides over line A, at which point, rider number two drops out. Rider number three picks up rider number four. Rider number three goes through the hoop while rider number four holds the mount. They ride over the changeover line where rider number three drops out, rider number four picks up rider number one; then they ride to the hoop, rider number four goes through the hoop while rider number one holds the mount, and finally the pair rides to the finish line. The winning team will be that whose first and fourth riders first cross the finish line mounted.

At each changeover, the next mount to go must remain behind the line until both previous mounts have crossed it. The rider who is to hold the mount at the hoop, does so by grasping the rein. The partner may not touch the hoop until they have handed over the mount.

HURDLE RACE

Required Equipment:

Two hurdles, 30 inches wide, 1 ft. high

Two hurdles, 30 inches wide, 2 ft. high

Two mugs, half full of water

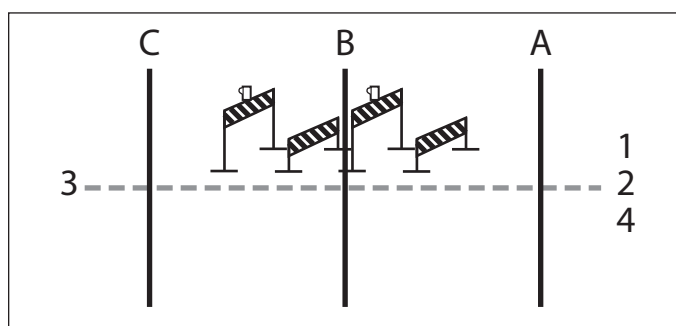

DETAIL: Four hurdles will be placed 6 ft. apart centered between lines A and C. They will be alternately 1 ft. and 2 ft. high, beginning with 1 ft. closest to line A. A mug, 1/2 full of water, will be placed on the center of the 2 ft. high hurdles.

This race is ridden in pairs with the number three rider of each team beginning behind line C (changeover line). Riders one and two will stand side by side at the start line, with rider number four behind them.

SECTION III: Competition

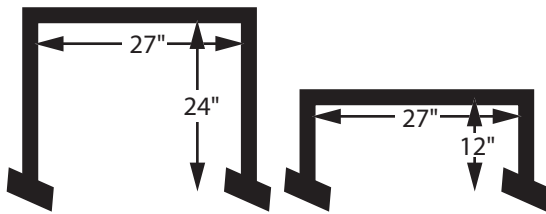

On the signal to start, riders number one and two will ride forward to the hurdles, where rider one will dismount and hand the mount to rider two. Rider one will then step over the first hurdle, crawl under the second hurdle, go over the third hurdle and under the fourth. Rider one will then remount and both riders will ride to the changeover line, where rider one will wait.

Rider two will turn around after crossing the line, then riders two and three will ride to the hurdles, where rider two will dismount and go under and over the hurdles. Rider two then remounts and both riders ride to the start/finish line where rider two will drop out of the race.

Rider three will turn around after crossing the line, then riders three and four will similarly complete the course, with rider three negotiating the hurdles. Number three drops out when riders three and four reach the changeover line and riders four and one will complete the course with rider four negotiating the hurdles.

The winning team will be the one whose final pair is first across the finish line, mounted, on their mounts.

At the changeover, the next mount must remain behind the line until both the previous mounts have crossed the line.

The rider holding the mount at the hurdles may grasp its rein before, or as they ride down the arena.

Should any hurdle be knocked over, or a mug fall off, the rider concerned must replace them and renegotiate all the hurdles again.

LITTER RACE

Required Equipment:

- One round plastic laundry basket
- One wooden or plastic 4' dowel, 1/2"—3/4" in diameter
- Four 1-quart cardboard milk cartons (litter) with the top (pouring end) cut off for a length of 7 3/4" OR four rounded plastic cartons (approximately same length as cardboard cartons)

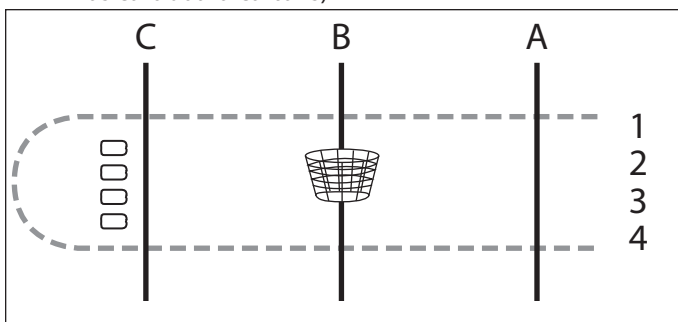

DETAIL: 3 yards behind line C, four cartons will be placed on the ground, the open ends will face away from line A. A laundry basket will be placed on line B for each team. Rider number one will ride to the far end; pick up a carton on the dowel and return to dump it into the basket. They will then continue back to the start and hand the dowel to rider number two. Riders two, three and four will similarly cross the changeover line, pick up a piece of litter and put it into the basket in succession. The winning team will be the team whose rider number four crosses the finish line, mounted and carrying the dowel.

Once a rider has selected their "litter," that is the ONLY litter they may pursue. If the litter chosen has been previously kicked over the changeover line into the playing field by a previous mount, the rider may pick it up in the playing field, but must then carry it back over the changeover line and then return to the playing field to complete the round. All four feet of all four mounts must cross the changeover line regardless of where the litter is located.

The riders must remain mounted and must not hold the litter by the hand when picking it up, carrying it on the dowel, or when dumping it. If the carton is smashed and can't be picked up, a rider may dismount to repair it, but must remount to pick it up on their dowel. Cartons may be weighted with sand if it is windy. Should the basket be knocked over, the rider concerned must set it up again, and replace all the litter in the basket, including their own, and proceed.

MUG SHUFFLE

Required Equipment:

- Four bending poles, placed 24-30' apart
- Two 12 oz. mugs—plastic, enamel or stainless steel recommended, with or without handles

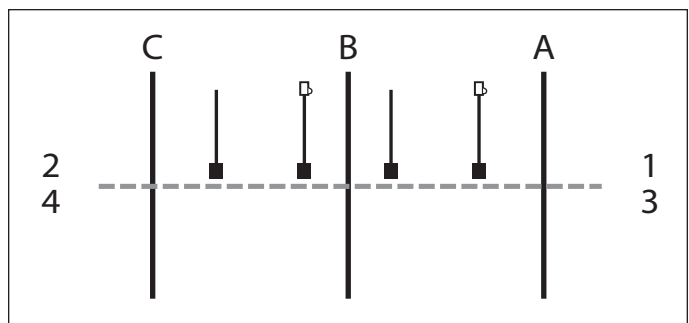

DETAIL: Four bending poles will be placed 24 to 30' apart centered between lines A and C. One mug is placed on top of pole 1, closest to line A; the second mug is placed on top of pole 3. Rider number one and rider three will be behind line A. Rider two and rider four will be behind line C.

On the signal to start, rider number one rides to pole 1 and moves the mug to pole 2, then moves the mug from pole 3 to pole 4. Riders number two, three and four will complete the course in the same manner up and down the arena succes-

SECTION III: Competition

sively. The winning team will be the one whose rider number four crosses the finish line first.

Dropped mugs must be placed on the correct pole before proceeding. Poles which are knocked over must be reset before proceeding. An attempt must be made to put the mug on the pole while mounted.

NEEDLE & THREAD RACE

Required Equipment:

Needle (wooden dowel, 10" long, 1-inch diameter with four (1/2 inch) holes drilled, starting one inch from the end allowing 1/2 inch between each hole.) The needle must be taped (with 2-inch masking tape) to a bending pole placed on line B. The pole should be a bending pole.

Thread (4 pieces) 18" cotton shoestrings, knotted at one end, wrapped with 2" of tape on the opposite end.

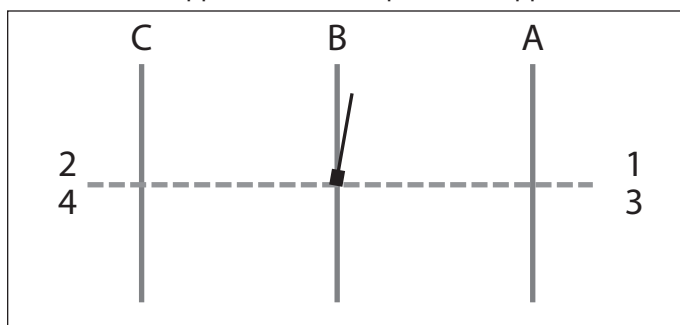

DETAIL: First and third riders of each team are mounted and located behind line A, carrying a thread. The second and fourth riders, of each team are mounted and carrying a thread behind line C. On the signal to start, the first rider on each team rides to the bending pole on line B; threads the needle and gallops on, crossing line C. The second, third and fourth riders of each team will similarly each complete the course, up and down the arena in succession. The winning team will be the team whose fourth rider is first to cross the finish line mounted and whose team has successfully threaded the needle four times. A successfully threaded needle means that the thread ends must be on each side of the needle—folding or bunching the thread is not allowed.

Each rider must thread the needle while mounted. If any previous threads are dislodged before the rider threads the needle, the rider may replace them mounted or unmounted.

If a bending pole is knocked over, the rider must reset the pole and replace the threads already placed by previous riders, mounted or unmounted. The rider must then proceed to thread the needle while mounted. If the pole is knocked over after the rider has successfully threaded the needle, the rider must reset the pole and rethread all dislodged threads either while mounted or unmounted.

NINE RING RACE

Required Equipment:

One bending pole with ring holder (see Ring Race for details)
 Nine round rubber rings (Hoover drive belts, 4" in diameter)
 One 3/4" diameter 4'-high post with a crosspiece with four cup hooks screwed into the bottom side (same as fishing)

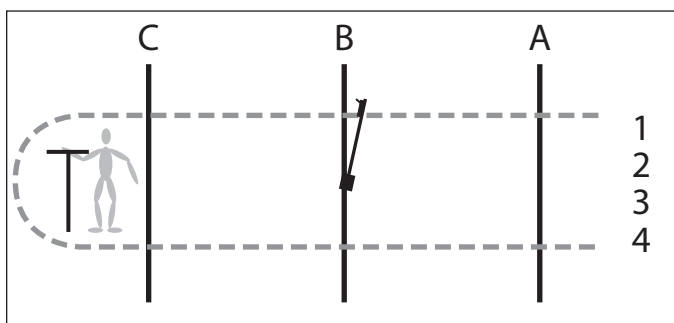

DETAIL: Bending pole is placed on line B with holder facing line A. Rider number five will be three yards beyond line C holding the 4' post. On each of the four hooks there will be two, 4-inch rings. The rings may be painted a bright color for visibility.

On the signal to start, rider number one, carrying a ring, rides to line B and places the ring on the center hook, then continues on to line C, takes two rings off the stand. Returning to line B, the rider leaves one ring on the holder and then goes on to pass the second ring to rider number two. Riders two, three and four then complete the course in exactly the same way in succession, with rider number four leaving both rings on the center holder before crossing the finish line. The winning team is the one whose rider number four is first over the finish line with nine rings correctly placed on the center line holder.

Rider number five may not lean the stand or give any form of assistance to the riders (they are considered part of the equipment). Rings dropped or dislodged from the stand must be picked up and replaced by the rider concerned, NOT by rider number 5.

OLD-SOCK RACE

Required Equipment:

One 5-gallon water bucket
 Five old socks (rolled up and sewn into a ball the size of a fist)

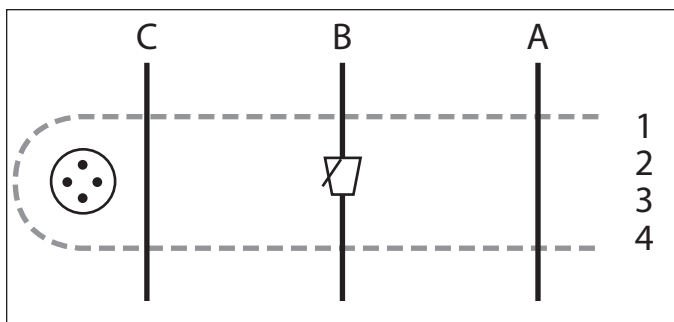

SECTION III: Competition

DETAIL: Place the water bucket on line B. If desired, draw or paint a 24" circle three yards behind the changeover line and place four of the socks in the circle, the fifth sock will be given to rider number one. On the signal to start, rider number one, carrying a sock, rides to the bucket on line B and drops the sock in it. The rider then continues to the far end to pick up a sock. The rider must dismount to pick up a sock and may dismount at any time after they have successfully dropped the sock into the bucket, but the rider and all four feet of the mount must cross line C (either mounted or unmounted) before returning for the handover regardless of where the sock was picked up. Riders number two, three and four will complete the course in the same manner in succession with rider number four dropping the last sock into the bucket (double dunking) on the way back. The winning team will be the team whose rider number four is first over the finish line mounted. If the socks are knocked out of the circle, they need not be placed back in.

PONY CLUB RACE

Required Equipment:

One heavy duty plastic trash bin, or similar, 23"-27" high, approximately 19" in diameter, with plywood circle bolted to bottom.

Eight letters—at least 8" by 8" and ¼ inch thick with a hole in the center top for hanging. The letters should be painted at least 5 inches tall.

One post, 7' high, with two cross bars, each with four hooks for hanging the letters

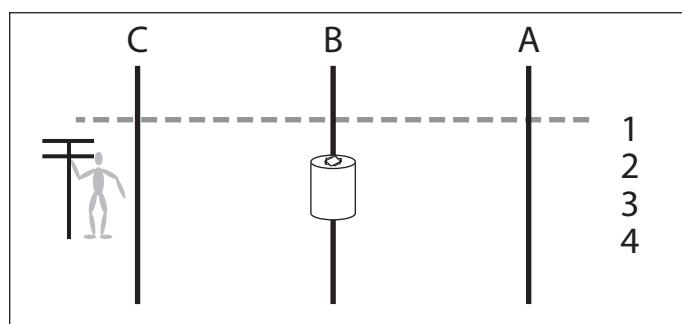

DETAIL: The trash bin is placed on line B, and on top of the bin are eight letters, spelling Pony Club, in random order. The letters should be shuffled and stacked on top of the bin in pairs. Each pair should be stacked diagonally on top of the next pair of letters. Behind the changeover line, on the 6-yard line, rider number 5 or a volunteer will hold the post, approximately 7' high, which has two cross bars each with four hooks screwed to the lower edge. On the signal to start, rider number one rides to the bin and picks up any two letters, rides to the rider number five and hangs the letters on the hooks in the correct spelling order before returning to the start/finish line. NOTE: The letters are written on both sides so that the final spelling is correct when observed from either side.

Riders two, three and four do likewise, the winning team being the first team with all the letters on the hooks in the

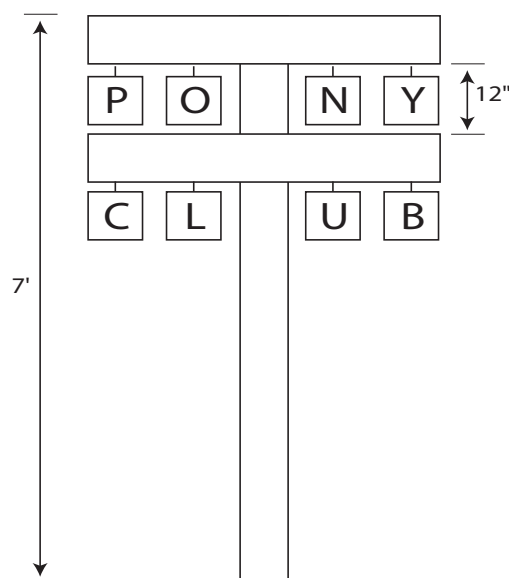

correct spelling and with rider number four crossing line A mounted. Rider number five may not help at any time and merely holds the post.

Letters dropped in attempting to hang them on the hooks may be picked up by dismounting. The rider must remount and then place the letters when mounted. Provided they have been correctly hung, letters blown off in the course of the race do not need to be replaced.

Letters placed in the wrong order must be corrected by the rider who placed the letter or letters. If the error is not noted until subsequent riders have placed their letters, the subsequent riders must retrace their actions back to the rider who made the error to be corrected and re-start from that point.

PONY EXPRESS

Required Equipment:

Four bending poles

Four weighted envelopes

One large pillowcase

DETAIL: The bending poles will be set in a straight line, two on each side of line B, 24 to 30 feet from line B. The remaining two poles should be set 24 to 30 feet, one on either side of the first two poles. Refer to diagram. The four weighted envelopes will be placed on the ground at line B. Riders

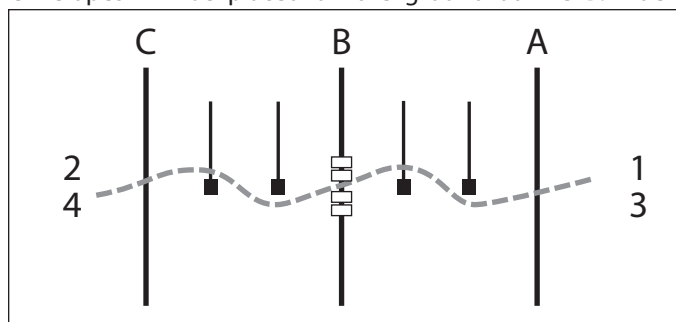

SECTION III: Competition

number one and three will be mounted behind line A. Riders number two and four will be mounted behind the changeover line. Rider number one will be given a pillowcase.

At the signal to start, they will ride down, weaving through the bending poles, to line B, where they will dismount, pick up an envelope, put it in the pillowcase before remounting, mount, and weave the remaining poles keeping the same pattern. The rider must be mounted passing the second bending pole, and must have remounted prior to passing the third bending pole. Upon crossing the changeover line, rider number one will handoff the pillowcase to rider number two. Riders two, three and four will complete the course in the same manner, passing up and down the arena successively. The winning team will be the team whose fourth rider crosses the finish line first, carrying the pillowcase containing four envelopes.

POSTMAN'S CHASE

Required Equipment:

- Five bending poles, placed 24-30' apart
- Four weighted envelopes
- One large pillowcase

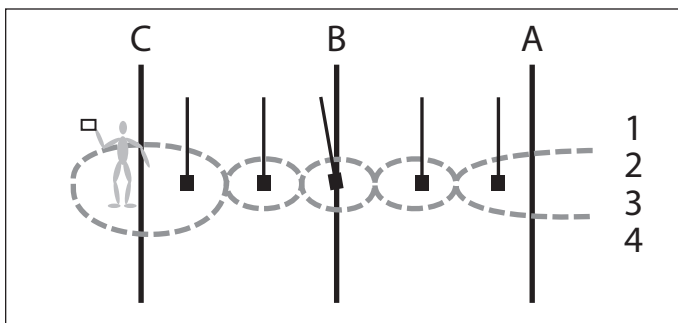

DETAIL: Five bending poles will be placed 24' to 30' apart, midway between lines A and C. (Same as setup for Bending Race.) Rider number 5 or a volunteer will stand unmounted, and holding the four letters, 3 yards beyond the changeover line. On the signal to start, rider number one carrying a pillowcase will weave through the bending poles, and across the changeover line, where rider number five will hand them a letter. The first rider will place the letter in their pillowcase before re-crossing the changeover line, returning by weaving through the bending poles past line A, where they will hand the pillowcase to rider number two. The second, third and fourth riders will similarly collect a letter from rider number five. The winning team will be the team who is first over the finish line, mounted and with four letters in the pillowcase.

Rider number five must remain beyond the changeover line during the entire game. Rider number five may assist by holding the inside rein of the rider only while rider places letter in pillowcase.

POTATO RACE

Required Equipment:

- Five potatoes
- One 5-gallon water bucket

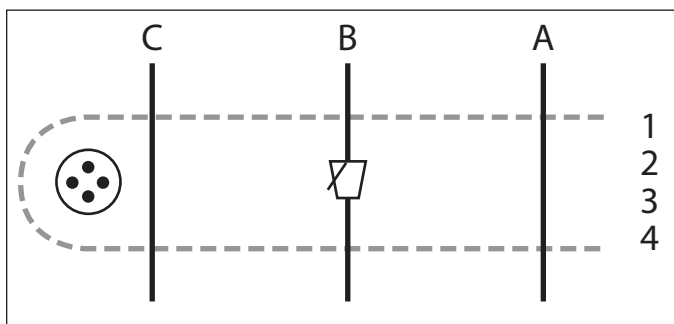

DETAIL: 3 yards behind the changeover line there will be four potatoes for each team, within a 24" diameter circle for visibility if desired. On the centerline place the 5-gallon bucket.

On the signal to start, rider number one, carrying a potato, will ride to the team's bucket and drop the potato into it. The rider then continues to the far end to pick up a potato. The rider must dismount to pick up a potato and may dismount at any time after they have successfully dropped the potato into the bucket, but the rider and all four feet of the mount must cross line C (either mounted or unmounted) before returning for the handover regardless of where the potato was picked up.

Riders two, three and four will complete the course in the same manner in succession, with rider number four dropping the fifth potato in the bucket on the way back (double dunking). If the potatoes are knocked out of the circle, they need not be placed back in.

PYRAMID RACE

Required Equipment:

- Two heavy duty plastic trash bins, or similar, 23-27" high, approximately 19" in diameter, with plywood circle bolted to bottom.
- Four plastic containers approximately 7" square and 3 3/4" deep partially filled with sand or sawdust to weigh 11lb or more.

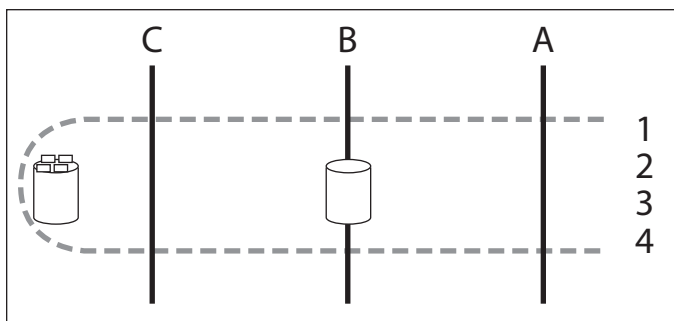

DETAIL: There will be a trash bin on the center line and the second bin three yards beyond the changeover line. There

SECTION III: Competition

will be four plastic containers placed on the bin beyond the changeover line.

On the signal to start, rider number one will ride to the changeover line and collect a container which will then be placed on the bin on the center line. Rider one then proceeds to the start/finish line. Rider number two rides to the changeover line, collects a container and stacks this on top of the previous container placed on the center line bin by rider one. Rider numbers three and four repeat the process until all containers have been restacked on the center line bin. The winning team will be the one whose rider four is first over the finish line, with all four cartons stacked on the center line bin.

QUOITS & CONE

Required Equipment:

- Four plastic or rubber quoits/rings, approximately 6" in diameter, with at least 4" opening
- One tennis ball
- One 18" traffic cone

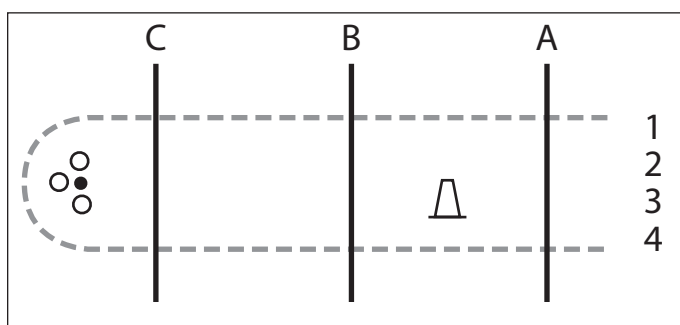

DETAILS: Three rubber quoits and a tennis ball for each team will be placed within a marked ring 3 yards behind line C. A cone will be placed 15' from line A.

Rider number one, carrying a quoit, rides to the cone, places the quoit over the cone, continues to line C, dismounts, picks up a quoit, remounts and returns to line A and hands it off to rider number two. Riders two, three and four will complete the course in the same way in succession, except rider number four picks up and places the tennis ball on the cone on the way back to the finish line. With four quoits and a tennis ball on the cone, the winning team will be the one whose rider number four is over the finish line.

RING RACE

Required Equipment:

- Two bending poles with ring holders
- Five round rubber rings (Hoover drive belts 4" in diameter)

DETAIL: One bending pole is placed 15 yards from line A with a ring holder (2" x 2" x 20" piece of wood in which four sections of 1/2" wooden dowel, 3" long, have been set and glued at 5" intervals) securely taped on with masking tape. The four-ring holder is to face line A. The second pole will be placed at line C with a single ring holder (2" x 2" x 10", 1/2" dowel, 6" long at center) taped on. The single ring holder is to

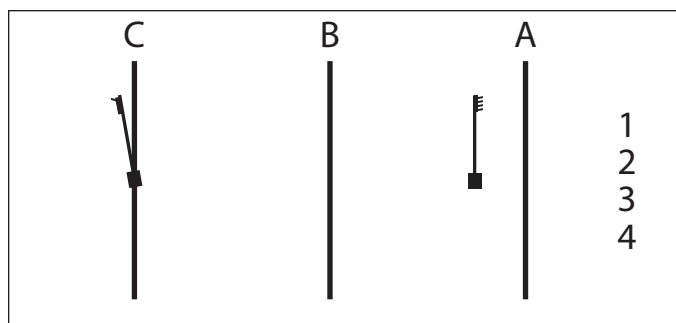

face away from the starting line (line A). The rings may be painted a bright color for visibility.

Rider number one carrying a ring, will ride to the far end of the arena and hang the ring on the dowel. Then rider number one rides back, collecting a ring from the pole near line A and hands the ring to the rider number two. Riders two, three and four will complete the course in the same manner, with the rider number four carrying the last ring over the finish line.

Should the ring be dropped or knocked off the ring holder dowel (line A), the rider must dismount, replace the ring, remount and take the ring from the dowel while mounted.

If a ring placed by a previous rider is knocked down in an attempt to place the ring on the dowel (line C), the rider must dismount and may replace that ring while unmounted. However, each rider must place their own ring while mounted. If either holder is knocked over, the rider must dismount and reset it. If the rider has not yet taken or placed a ring, they must remount to do so.

ROPE RACE

Required Equipment:

- Four bending poles, placed 24'-30' apart
- 3' long rope (cotton preferred, at least 1/2" thick, no knots)

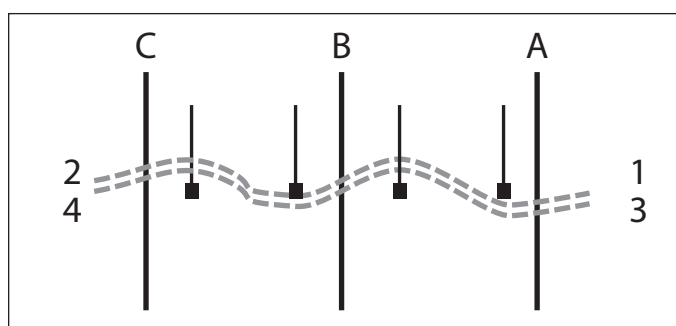

DETAIL: The bending poles are placed 24' to 30' apart midway between lines A and C. Riders number one and three will be behind line A. Riders two and four will be behind line C. Rider number one, carrying the rope rides down the line of bending poles passing them on alternate sides, crosses the changeover line where the second rider will grasp the other end of the rope. Both riders will then ride back weaving the bending poles, each rider holding one end of the rope, and

SECTION III: Competition

crossing line A. Rider number one releases the end of the rope and rider number three grasps it. Riders two and three weave the bending poles, holding each end of the rope, and cross the changeover line, where rider number two releases the end of the rope and rider number four grasps it. Riders three and four ride back, weaving the bending poles, each holding one end of the rope until they cross line A. The winning team will be the team whose riders three and four — each holding one end of the rope — have both crossed the finish line first. The rope must be grasped behind lines A or C. No knots are permitted on either end of the rope.

NO HOLDING HANDS! The rider's grip must be on the rope.

RUBBER DUCKY

Required Equipment:

- One five gallon bucket $\frac{3}{4}$ full of water
- One three gallon bucket $\frac{3}{4}$ full of water
- One heavy duty plastic trash bin, or similar, 23-27" high, approximately 19" in diameter, with plywood circle bolted to bottom
- Three 3" rubber ducks
- One large pillowcase

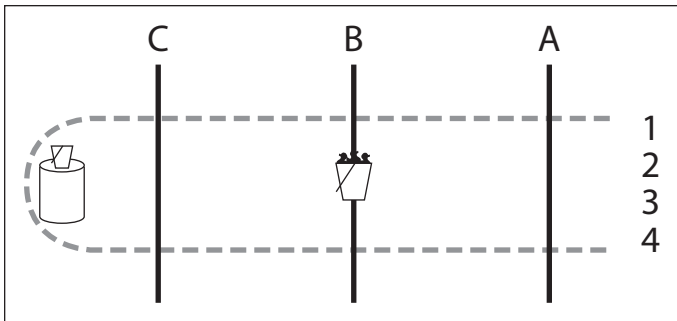

Detail: The five-gallon bucket with water and three ducks is placed in the lane in line with the second pole. The overturned bin is on the two-yard mark behind the C line, with the three gallon bucket of water placed on top of it. All riders start behind the A line, Rider 4 has the pillowcase.

Rider 1 rides to the bucket and collects a duck. Rider 1 then rides to the C line and places the duck into the three gallon bucket before returning to the A line. Riders 2 and 3 do the same as Rider 1. Rider 4, with the sack, rides to the C line, collects the three ducks from the three gallon bucket, places them in the sack, and returns to the A line.

At any time riders may collect ducks mounted or dismounted. All ducks must be in the sack before Rider 4 crosses the A line. Loss of water is not penalized. Riders who dismount to collect a duck from the first bucket, must remount before placing that duck into the three gallon bucket on the barrel.

SPILLERS POLE RACE/PONY CLUB POLE RACE

Required Equipment:

- One bending pole
- Eight lettered cylinders made of 2" PVC pipe, 6" long. Each cylinder will have one of the letters from the word SPILLERS (or PONY CLUB) repeated 3 times on the surface

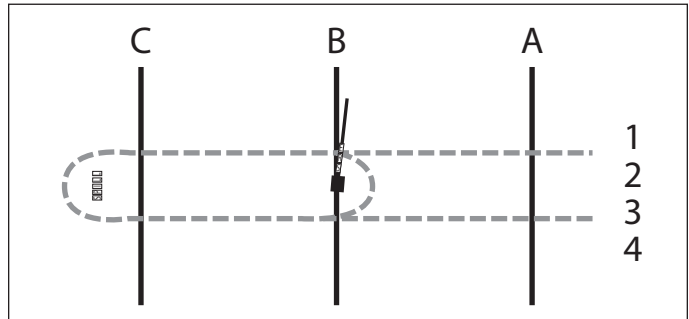

DETAIL: Three yards beyond the changeover line there will be eight lettered cylinders, with letters S,P,I,L,L,E,R and S (or P,O,N,Y,C,L,U,B) lined up in any order perpendicular to the changeover line. A bending pole (the spillers or Pony Club Pole) will be on the center line of the arena. Rider number one will begin with a cylinder lettered "S" (or "B").

On the signal to start, rider number one will ride forward to the SPILLER'S or PONY CLUB pole (bending pole) and slot the cylinder over the pole. Rider one continues to the far end, dismounts and collects the letter "R" (or "U"). They remount and return to the center where they slots the "R" (or "U")

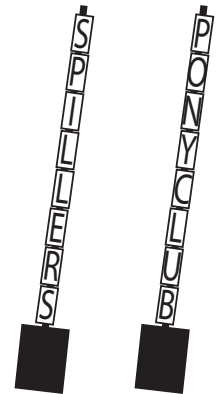

onto the pole. They then returns to the far end, dismounts and collects carton "E" (or "L"), remounts and rides to the start/ finish line to hand cylinder "E" (or "L") to rider two. Rider numbers three and four repeat the process until the word "SPILLERS" (or PONY CLUB) can be read from the top to the bottom of the pole. Rider four slots the final "S" (or "P") over the pole on the way back and crosses the finish line. The winning team will be the one whose rider four is first over the finish line, with the word "SPILLERS" (or PONY CLUB) spelled correctly from the top to the bottom of the pole. The rider and all four feet of the mount must cross line C (either mounted or unmounted) before returning, regardless of where the cylinder was picked up.

Letters placed in the wrong order must be corrected by the rider who placed the letter or letters. If the error is not noted until subsequent riders have placed their letters, the subsequent riders must retrace their actions back to the rider who made the error to be corrected and re-start from that point.

Cylinders placed in the wrong order, or with the letter upside down, must be corrected by the rider who placed the cylinder incorrectly.

SECTION III: Competition

STEPPING-STONE DASH

Required Equipment:

Six stepping stones

One 1" x 8" x 10' board (Optional)

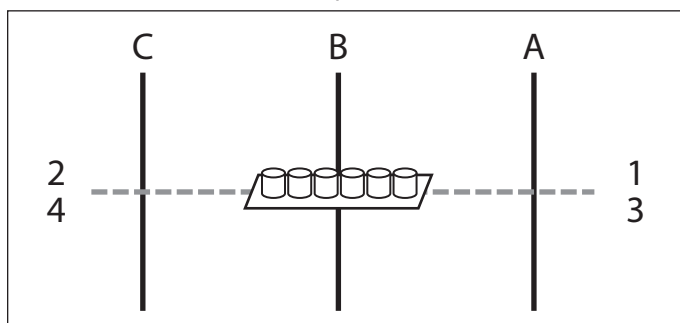

DETAIL: Six stepping stones (each stone is a plastic or metal tapered bucket or concrete, set upside down) placed one upside-down bucket's width apart, midway between lines A and C. Riders number one and three will be mounted behind line A; riders number two and four will be mounted behind the changeover line. On the signal to start, rider number one will ride to the stepping stones, dismount, and dash across (on top of) the stones while leading the mount, beginning with the stone closest to the rider's starting line and ending with the stone farthest from the rider's starting line, treading on each stepping stone and on the ground after the last. They will then remount before riding across the changeover line. Riders two, three, and four will similarly complete the course up and down the arena in succession. The winning team will be the team whose rider number four is first over the finish line, mounted. If a stone is missed, knocked over by a rider or a mount's foot, or the rider's foot hits the ground before the last stone is treaded, rider must reset the stone and redo all six stones.

No competitor is allowed to get help from the mount or its tack by holding onto the mane, the neck, the saddle, or any part of the bridle held close to the bit (leaning on the bridle for support).

STICK PEGGING RELAY

Required Equipment:

One heavy duty plastic trash bin, 23-27" high

One wooden or plastic 4' dowel, 1/2"—3/4" in diameter, rounded at both ends

Eight 6" tall pieces of 2"x4" wood

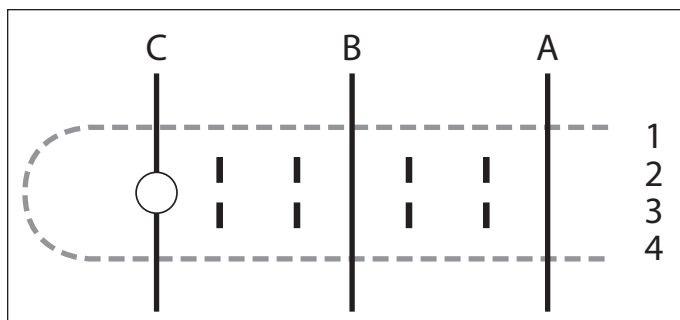

DETAIL: Plastic bin sits on line C. The eight wooden blocks, standing on end, will be placed in two lines (4 per line), 6-1/2 feet apart (width). Starting out from line B, the second and third blocks will be 3-1/2 feet from line B. From the second to first and third to fourth, the length will be 6-1/2 feet between blocks.

Rider number one, with stick held in right hand, rides down the left side of the lane (on rider's right), knocks down the first block in the left hand row with the stick, continues and makes a right hand turn around the end bin, returns down the right side of the lane, knocks down the first block of that row, continues to line A and passes the stick to the next rider, right hand to right hand. Riders two, three and four complete the course in the same manner, knocking down two blocks each in their consecutive order. The winning team is the one with the first number four rider crossing the finish line, stick in hand.

If a horse knocks down a block, the rider must replace it before continuing. If a rider knocks down a wrong block, it must be replaced before continuing.

SWORD RACE

Required Equipment:

Four or five bending poles, placed 24-30' apart

Four rings (Hoover drive belt 4" in diameter OR 4" diameter plastic rings), fastened to poles with rubber bands

One sword

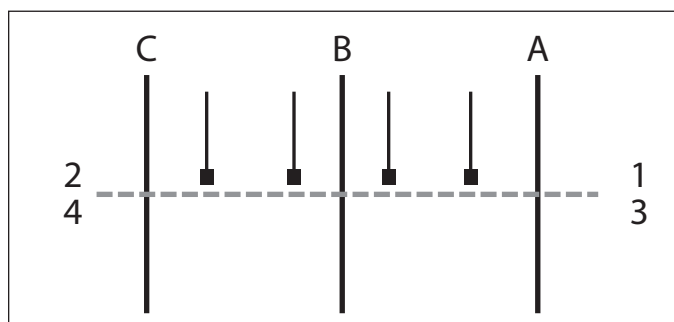

DETAIL: The bending poles are placed 24' to 30' apart. If 5 poles are used, put rings on 1, 2, 4 & 5.

The sword is a 2' wooden (blunt), 1/2" diameter dowel, with a 1' piece of 1/2"-diameter dowel taped at a right angle about 6" from one end. The sword may be made by notching handle and blade so they mesh for better fit.

Riders number two and four are mounted behind the line C. Rider number one, carrying the sword, will ride to one of the poles, pick up the ring on their sword, ride over line C and hand over the sword to rider number two. At no time may the sword be touched on the blade side of the crosspiece. Riders two, three, and four complete the course in the same manner, up and down the arena. When rider number four crosses the finish line mounted, they must have all four rings on the sword.

SECTION III: Competition

If a ring is dropped, the rider may retrieve it mounted or unmounted. If unmounted, the rider may replace it by hand on the sword and hold it until remounted and returned to where it was dropped, where the rider must let go of the ring to resume the race. The rings may not be touched by hand, and the sword may not be touched above the crosspiece, except when correcting an error.

The rider may ride straight and need not weave through the poles. If a pole is knocked over, it need not be reset. If the ring is still attached to the downed pole, it may be collected either mounted or unmounted, using the sword or the hand.

TACK SHOP RACE

Required Equipment:

Two heavy duty plastic trash bins, or similar, 23-27" high, approximately 19" in diameter, with plywood circle bolted to bottom.

One bending pole topped with a "money box", 6" diameter plastic container with sides no taller than 1-½" which are vertical or angled out slightly with dowel rod attached to fit down into bending pole

One plastic grooming tray

One coin—4" in diameter, plywood or stiff material

Four pieces of tack: sponge, dandy brush, comb, rubber curry comb, or other such suitable items

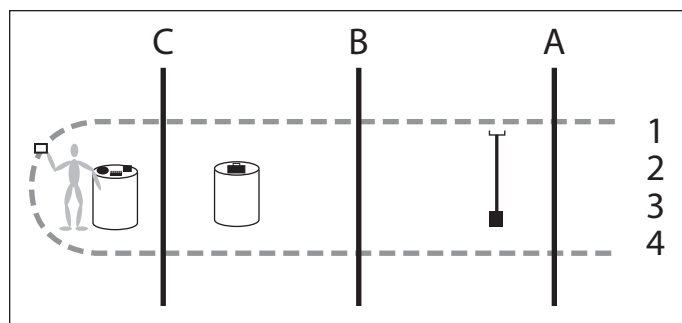

DETAIL: One bending pole topped with the "Money Box" will be placed fifteen yards from the start line. Fifteen yards from the changeover line will be one trash bin with a plastic grooming tray on top. Rider number five or a volunteer begins standing behind a trash bin placed three yards beyond line C with 4 tack items lying on the trash bin. Rider number one will start carrying the coin.

On the signal to start, rider number one will ride forward to the "money box" on the bending pole and deposit the "coin." Rider one continues to collect the grooming tray by the handle and then rides to rider number five or a volunteer who puts any one of the items in the grooming tray. Rider one then returns the grooming tray to the first bin. They then ride to the money box, collects the coin and hands it to rider two. Rider numbers two, three and four repeat the process. The winning team will be the one whose rider four is first over the finish line carrying the coin.

If an item is dropped behind the changeover line, either the rider, rider number 5, or a volunteer may pick it up. The item

must be in the tray before the rider re-crosses the changeover line. Number 5 or the volunteer may hold the rein of the mount behind the changeover line.

Weights may be placed in the tack box in windy conditions. In such cases, the weights are considered to be part of the equipment and must be replaced if the tack box is knocked over. Grooming tray must be carried by the handle.

THREE-LEGGED RACE

Required Equipment:

One feed sack

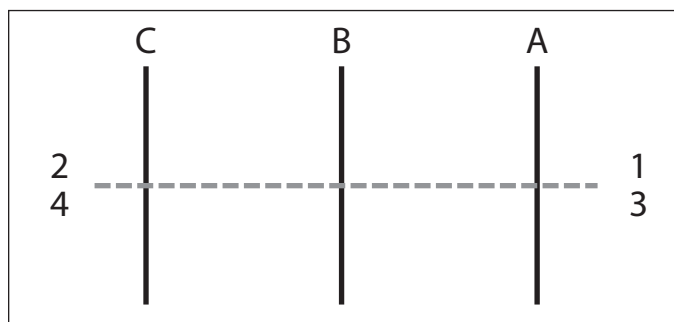

DETAIL: Riders number one and three will be mounted behind line A; riders two and four will be unmounted, holding their mounts, standing behind the changeover line.

On the signal to start, rider number one carrying the sack rides to the changeover line where they pass the sack to rider two and dismounts. Riders one and two place one foot each in the sack before crossing line C, then proceed to line A leading their mounts. After crossing line A the sack is handed to rider number three who rides to the changeover line, passes the sack to rider four and dismounts. Riders three and four place one foot each in the sack and proceed to line A leading their mounts. The winning team will be the one whose riders number three and four each with one foot in the sack, leading their mounts, cross the finish line first. All twelve legs must cross the finish line to complete the race.

Riders one and three may dismount any time after crossing line A but rider and mount must cross the changeover line before getting into the sack.

Riders one and three may pass the sack to riders two and four before crossing the changeover line if they wish. The sack must remain above the knees when running.

Riders and mounts must be behind the line before moving off in the sack and at the changeovers between riders one and two and rider three.

SECTION III: Competition

THREE-MUG RACE

Required Equipment:

Four bending poles, placed 24'-30' apart

Three 12-14 oz plastic, enamel or stainless-steel mugs, with or without handles, placed inverted on the first three poles

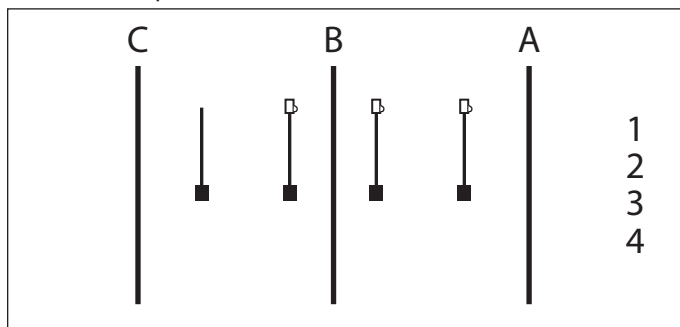

DETAIL: On the signal to start, rider number one goes forward to move the mugs from post to post in the following order: Mug from post three to post four; mug from post two to post three; mug from post one to post two, after which they return and cross line A. Rider number two then moves the mugs back from post two to post one; from post three to post two; and from post four to post three, after which they cross line A. Rider three and four complete the course in the same manner. The winning team will be the team whose number four rider is the first over the finish line, mounted. If knocked over, poles must be reset.

TOOL BOX RACE

Required Equipment:

One heavy duty plastic trash bin, or similar, 23-27" high, approximately 19" in diameter, with plywood circle bolted to bottom.

One plastic grooming tray

Four plastic or wooden toy tools

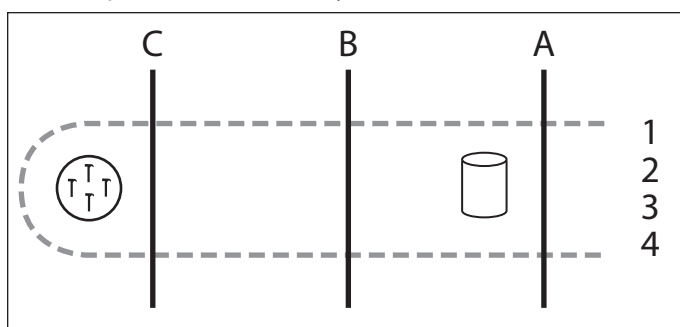

DETAIL: One trash bin will be placed fifteen yards from the start line. Three yards beyond line C will be 4 plastic or wooden tools, which may be placed within a 24" diameter painted circle, for visibility, if desired. Rider number one will start carrying the tool box.

On the signal to start, rider number one carrying the tool box will ride forward to the bin and place the tool box on the bin. Rider one then continues to the far end of the arena, dismounts, collects a tool, remounts and returns to place the

tool in the tool box before crossing the start/finish line. Rider numbers two, three and four repeat the process with rider four collecting the tool box by the handle and carrying it across the start/finish line.

Rider four must place the tool in the tool box before picking the tool box up to cross the finish line.

The tool box must be carried by the handle when crossing the start/finish line.

Weights may be placed in the tool box in windy conditions. In such cases, the weights are considered to be part of the equipment and must be replaced if the tool box is knocked over.

TWO-FLAG RACE

Required Equipment:

Two 18" traffic cones, cut down to leave 4" diameter opening

Two flags, 4' long

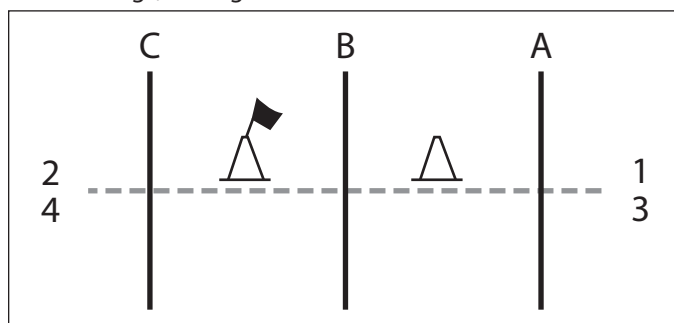

DETAIL: The poly-vinyl traffic cones are 18" high, with square platform base. The top of the cone is to be cut off, so that the inside diameter at the top is 4." The flags are 4' wooden dowels, 1/2" in diameter, with a piece of cloth 6" x 8" attached to one end of each dowel. The cones will be placed 15 yards from line A and 15 yards from the changeover line. In the holder nearest the changeover line one flag will be placed.

Riders number one and three will be mounted behind line A, riders number two and four will be mounted behind the changeover line. At the start rider number one, carrying a flag, will ride to the first cone and put the flag in it, then will ride to the second cone, remove the flag, and hand it over to rider number two. Riders two, three and four will similarly complete the course up and down the arena in succession. The winning team will be the team whose rider number four is the first over the finish line, mounted and carrying a flag.

SECTION III: Competition

WINDSOR CASTLE RACE

Required Equipment:

- One 26" traffic cone with turret holder in place
- One 5-gallon water bucket 1/2 full of water
- One turret
- One orb (croquet, bocce ball or practice (plastic) polo ball spray-painted gold)

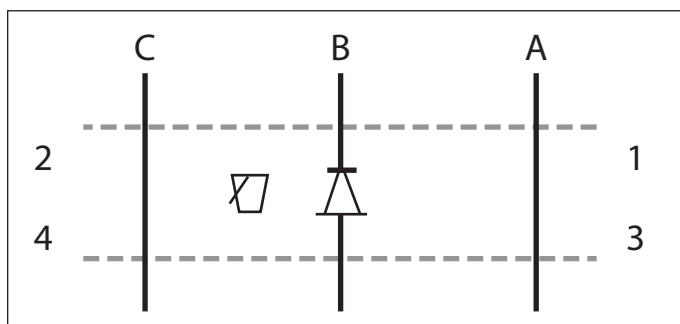

DETAIL: One traffic cone, representing the castle, will be placed on the centerline. The moat (water bucket) is placed midway between the center and changeover lines.

Riders number one and three are behind the start/finish line, and riders number two and four are behind the changeover line. Rider number one carries the turret and rider number two carries the orb. On the signal to start, rider number one takes the turret and rides to the castle, placing the turret on the turret holder. They then ride to cross line C. Rider number two rides to the castle and places the orb on top of the turret, then crosses the start/finish line. Rider number three is the robber, who rides to the castle, steals the orb, and drops it into the moat (bucket) before going on to cross line

Rider number four rescues the Orb from the Moat, replaces it on the Turret and continues on to cross the finish line. The orb may be retrieved from the moat either mounted or unmounted. A reasonable attempt should be made to place or remove the orb or turret from the castle while mounted. In all instances, the rider must remount to continue the race.

The winning team is the team whose rider number four is first over the finish line, mounted, and having completed correctly all the phases of the race. The rider shall be mounted for all phases of the race, except as already specified for retrieving the orb out of the moat.

If the turret or the orb is dropped (or if the rider misses the moat when dropping the orb), they may be retrieved mounted or unmounted. If the turret or the castle is knocked over, it must be reset either mounted or unmounted.

WIZARD'S CASTLE

Required Equipment:

- 2 traffic cones 18" high
- 2 cones from a Flag Race 1 flag
- 1 sword
- 1 tennis ball

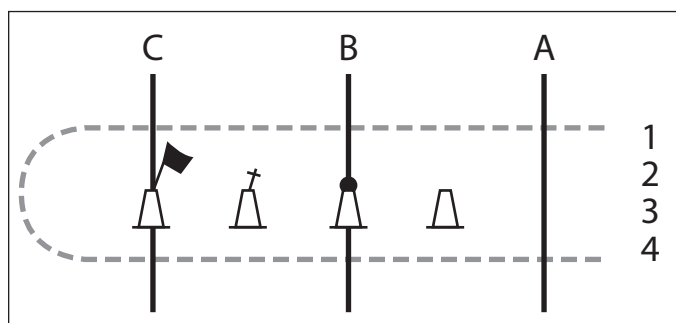

DETAIL: On line C there will be a cut-down cone with a flag. Midway between line C and line B a traffic cone will be placed with a sword. On line B, there will be a traffic cone with a tennis ball on top. The other cut-down cone will be placed midway between line A and line B.

On the signal to start, rider number one rides to line C, removes the flag from the cone (the evil wizard's castle) and returns to place the flag in the pylon closest to line A. This is their own castle. Rider number one rides over the finish line. Rider number two takes the tennis ball (golden orb) from the cone on the centerline and drops it into the center of the cone on line c (removing the golden orb takes away the evil wizard's power). Rider number two crosses the finish line. Rider number three takes the sword from the cone midway between lines B & C, returns to the finish line, and hands off the sword to rider number four. Rider number four plunges the sword into the center of the cone on line C (this will kill the evil wizard).

The winning team will be the one whose rider number four crosses the finish line with a sword and orb in the wizard's castle, a flag in their own castle, and all pylons remaining upright. The sword may not be touched above the cross-piece, except when correcting an error.

SECTION III: Competition

Article 52—Games for Pairs Competition

BALL AND BUCKET RACE

Required Equipment:
 One 5-gallon water bucket
 Three tennis balls

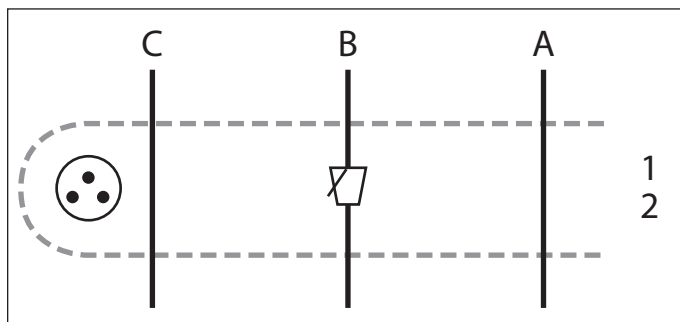

DETAIL: Three yards behind line C there will be two tennis balls which may be placed within a 24" diameter painted circle for visibility if desired. On line B will be the bucket. On the signal to start rider number one, carrying a ball, will ride to the bucket and drop the ball into it. The rider then continues to the far end to pick up a ball. The rider must dismount to pick up a ball and may dismount at any time after they have successfully dropped the ball into the bucket, but the rider and all four feet of the mount must cross line C (either mounted or unmounted) before returning for the handover regardless of where the ball was picked up. Rider two completes the event in the same manner dropping the last ball into the bucket on the way back (double dunking). If the balls are knocked out of the circle, they need not be placed back in.

BALL AND CONE RACE

Required Equipment:
 Two traffic cones 18" high
 Two tennis balls

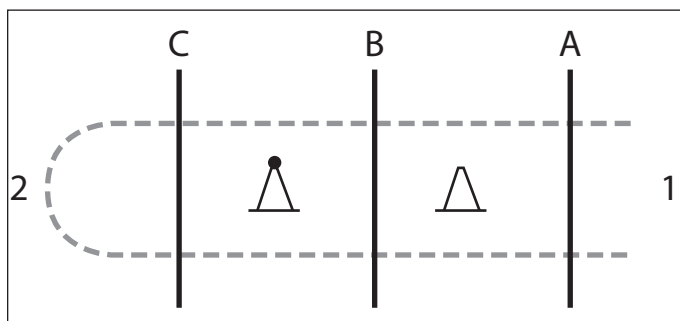

DETAIL: There will be two cones, each one placed 15 yards from lines A and C. A tennis ball will be placed on the cone closest to line C. Rider one will be mounted at the start line and rider two at the changeover end. Rider one carries a tennis ball and on the signal to start, rides to the first cone and places the ball on it; they then ride to the second cone, collects the ball and hands it to rider two. Rider two completes the course in the same manner. The winning team

is the one whose rider two is the first over the finish line carrying the ball.

BALL AND RACQUET

Required Equipment:
 Four bending poles, placed 24-30' apart
 One tennis ball
 One tennis racquet

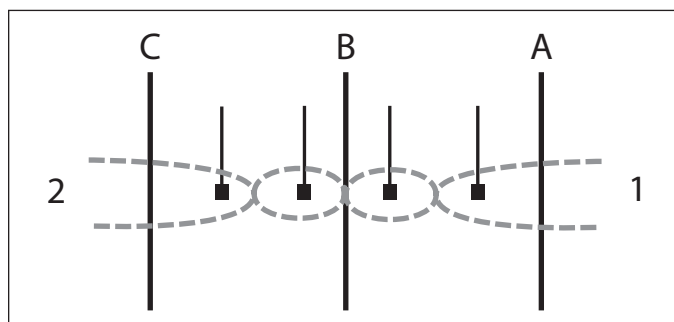

DETAIL: Four bending poles will be placed 24 to 30' apart centered between lines A and C. Rider number one will be behind line A, rider number two behind line C.

Rider number one will carry the tennis racquet on which is placed a tennis ball. On the signal to start, rider number one will ride down the line, through the bending poles carrying the tennis ball on the racquet. The tennis ball must not be touched by hand, except when being picked up. On arrival at line C, rider number one will hand the racquet and ball to rider number two, the tennis ball still being untouched by a hand. Rider number two will complete the course in the same manner, down the arena. The winning team will be the one whose rider number two crosses the finish line first with the tennis ball on the racquet.

Should the tennis ball be dropped, the rider must pick it up, and resume the course again from the point where the ball was dropped. The ball need not be placed on the racquet until this point is reached. Should the ball and/or racquet be dropped over the handoff line either rider may retrieve the ball, mounted or dismounted and place the ball on the racquet of the next rider to go.

Each racquet will have a colored band around the handle 3" below the head and competitors hands must be behind this band.

BALLOON RACE

Required Equipment:
 One board, 1" x 8" x 8'—10'
 Three round balloons (not elongated)
 One lance (wooden or plastic 4' dowel, 1/2"—3/4" in diameter), with 1" brad driven into one end so that no more than 3/8" of the brad remains)

DETAIL: The 8 to 10-foot board with three 1" grooves cut into each side of the board (see diagram) will be centered in line B. (Can be the same board used in Stepping Stone Dash). Three round balloons (two on one side, one on the other) will

SECTION III: Competition

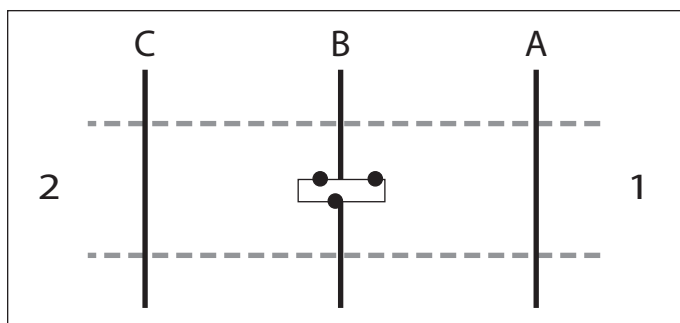

be inserted into the grooves in the board. Rider number one will be at line A and rider two will be behind the changeover line. Rider number one, carrying the lance, rides to the balloons, bursts one, rides on to the changeover line and hands the lance to rider number two. Rider two completes the course in a similar manner, bursting a balloon. The winning team will be the team whose rider number two is first over the finish line, mounted and carrying the lance.

Each rider (not the mount) must break a balloon. In the event all of the balloons are burst before the last rider goes, the team will be disqualified from the game.

BENDING RACE

Required Equipment:

- Five bending poles, placed 24-30' apart
- One baton

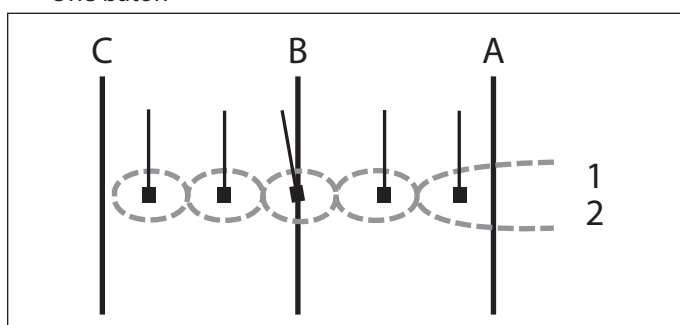

DETAIL: A bending pole is a plastic pole in a metal, concrete or rubber cone base (total height 4'6"). The baton is 10-12" long, 1" in diameter. Rider number one, carrying the baton, rides across line A, down the line of bending poles, passing them on alternate sides, turns around the last pole and returns in the same manner, crossing line A. Once behind line A, they hand the baton to rider number two. Rider two completes the course in the same manner. The winning team will be the team whose second rider crosses the finish line first, mounted and carrying the baton.

BOTTLE RACE

Required Equipment:

- Two heavy duty plastic trash bins, or similar, 23-27" high, approximately 19" in diameter, with plywood circle bolted to bottom.
- Two 1-liter plastic bottles, 1/2 filled with sand

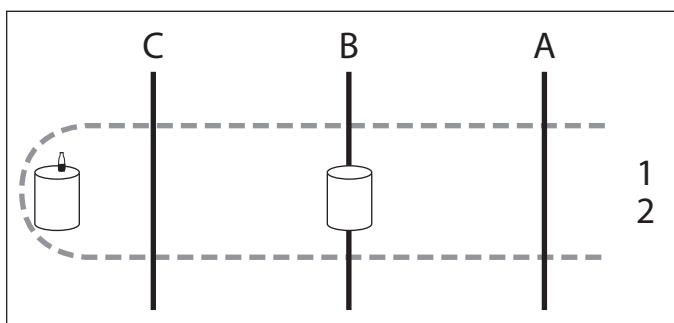

DETAIL: There will be a trash bin as described above placed upside down on the centerline and a similar bin three yards behind the changeover line. On the bin beyond line C will be one plastic bottle. On the signal to start, rider number one, carrying a similar bottle, will ride to the first bin and place the bottle upright on the bin. They will then continue to the far end to pick up the bottle from the bin there and return, crossing line A to handoff to rider number two. Rider two completes the course in a similar manner, placing the bottle on the empty bin and collecting the bottle from the other bin. Bottles must remain upright on the bins throughout the race. The winning team will be the team whose rider number two crosses the finish line first, mounted, carrying a bottle.

THE CANADIAN RACE

Required Equipment:

- Two traffic cones 18" high
- Four bending poles, placed 24-30' apart
- Two tennis balls
- One plastic hockey stick, length approx. 40" (street hockey stick is best)

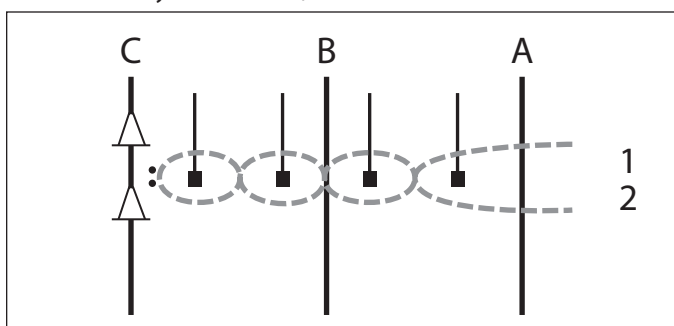

DETAIL: Four bending poles will be placed 24 to 30' apart centered between lines A and C. Two cones will be placed 6' apart on line C creating the "goal." Two tennis balls spaced 1 foot apart will be placed 3 feet from line C lined up with the goal opening.

On the signal to start, rider number one weaves through the bending poles carrying the hockey stick and hits one ball; the

SECTION III: Competition

rider must continue to hit the same ball until it goes through the goal posts (cones). Rider one will then return weaving through the bending poles and hand off the hockey stick to rider two. Rider number two completes the course in the same manner. The winning team will be the one whose rider two is first over the finish line, mounted and carrying the hockey stick.

All four bending poles and the cones must be upright.

In the event that a mount kicks a ball through the goal, that ball must be brought back over the goal line by the rider whose mount kicked it over the goal line. The ball does not have to go back to its original position.

Riders must bend the poles when returning to the start/finish line but the bending pattern need not be a continuation of the weave on the way down.

CARTON RACE

Required Equipment:

- Four bending poles, placed 24-30' apart
- Two plastic or cardboard litter cartons
- One 5-gallon water bucket

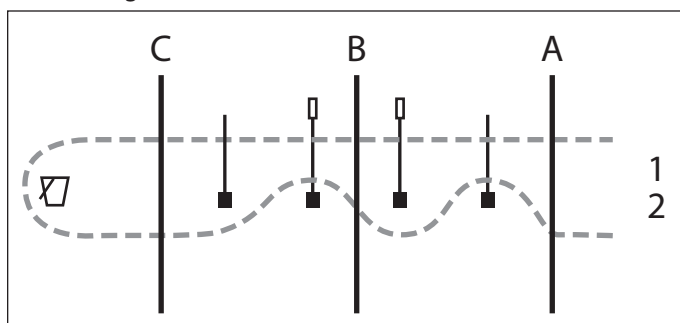

DETAIL: Four bending poles will be placed 24 to 30' apart centered between lines A and C. One carton each is placed on top of poles two and three. The bucket is placed 3 yards beyond the changeover line. Riders number one and two will be behind line A.

On the signal to start, rider number one collects a carton from any pole, rides to the bucket, drops the carton in the bucket and returns, bending the poles, to the start/finish line. The rider does not bend the poles until after they have placed the carton in the bucket. Rider number two completes the course in the same manner. The winning team will be the one whose rider number two crosses the finish line first with both cartons in the bucket. Poles which are knocked over must be reset before proceeding.

EGG AND RACQUET RACE

Required Equipment:

- Three bending poles
- One solid wooden craft store egg
- One tennis racquet

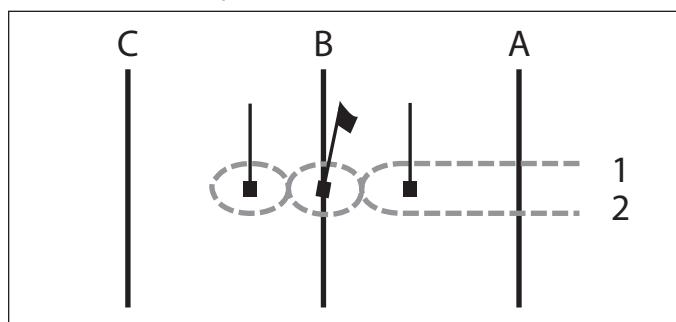

DETAIL: Three bending poles will be put up 24' to 30' apart.

Rider number one will carry the tennis racquet on which is placed an egg. On the signal to start, rider number one will ride up and down the line through the bending poles carrying the egg on the racquet. The egg must not be touched by hand, except when being picked up. On arrival at the finish line, rider number one will hand the racquet and egg to rider number two, the egg still being untouched by hand. Rider two completes the course in the same manner. The winning team will be the team whose rider number two is first over the finish line carrying the egg on the racquet. Should the egg be dropped, the rider must pick it up and resume the course again from the point where the egg was dropped. The egg need not be placed on the racquet until this point is reached. Should the egg and/or racquet be dropped over the handoff line, either rider may retrieve the egg, mounted or unmounted, and place the egg on the racquet of the next rider to go. Each racquet will have a colored band around the handle 3" below the head and competitors' hands must be behind this band.

FISHING RACE

Required Equipment:

- One 5 gallon water bucket
- Two wooden fish 1/2" thick, with a small screw eye in the mouth end
- One wooden or plastic 4' dowel, 1/2"—3/4" in diameter, with a cup hook on one end
- One 3/4" diameter 4'-high post with a cross piece with four cup hooks screwed into the bottom side

DETAIL: The bucket containing the two wooden fish will be placed on line B. A volunteer holder will stand 3 yards behind the changeover line holding the 4' post.

On the signal to start, rider number one, carrying the dowel, will ride to the bucket, hook a fish on the end of the dowel and continue to the volunteer. The volunteer unhooks the fish and secures it on one of the hooks on the post. All 4 feet of the mount must cross and remain behind the line C until the holder has correctly placed the fish on a hook, then

SECTION III: Competition

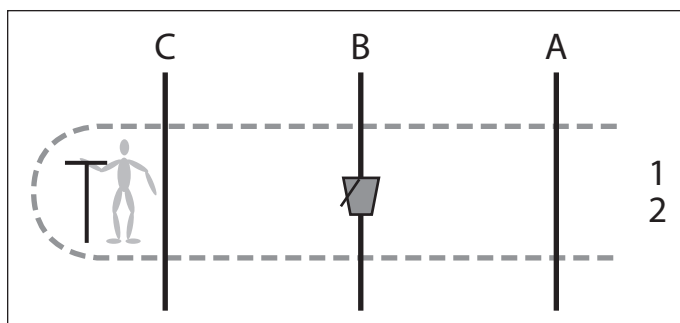

they ride to the start line to handoff the dowel to rider number two. Rider two completes the race in the same manner. The winning team will be the team whose rider number two crosses the finish line, carrying the dowel and with both fish on hooks.

If a fish is dropped while handing over to the person holding the post, that person may pick it up and put it on the post; it need not be replaced on the rider's dowel. The holder shall signal by raising a hand that the fish is securely hung, so that the judges can determine when the rider may properly return. Failure to so signal, however, shall not carry a penalty.

SPECIAL RULES: The rider must hook the fish from the bucket while mounted. If the bucket is knocked over before the fish is hooked, the rider must reset the bucket, replace all the fish and then proceed to hook the fish while mounted.

If the bucket is knocked over after the fish is hooked, the rider must reset the bucket and replace the remaining fish. Any correction may be made mounted or unmounted using the hand or the hook. If the hook is used to correct the error, the rider may remove the fish by hand and replace it by hand after the error is corrected.

FIVE RING RACE

Required Equipment:

- One bending pole with ring holder (see Ring Race for details)
- Nine round rubber rings (Hoover drive belts, 4" in diameter)
- One 3/4" diameter 4'-high post with a crosspiece with four cup hooks screwed into the bottom side (same as fishing)

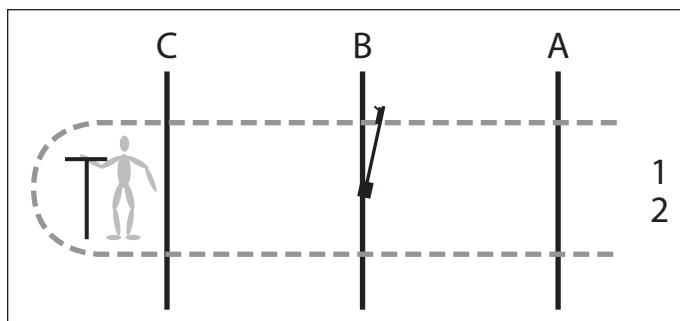

DETAIL: Bending pole is placed on line B with holder facing line A. Rider number five will be three yards beyond line C holding the 4' post. On each of the four hooks there will be

two, 4-inch rings. The rings may be painted a bright color for visibility.

On the signal to start, rider number one, carrying a ring, rides to line B and places the ring on the center hook, then continues on to the line C, takes two rings off the stand. Returning to line B, the rider leaves one ring on the holder and then goes on to pass the second ring to rider number two. Rider number two places the ring on the center hook, rides to line C, takes the remaining two rings and places both on the center holder before crossing the finish line. The winning team is the one whose rider 2 is first over the finish line with rings correctly placed on the center line holder.

The post holder may not lean the stand or give any form of assistance to the riders. Rings dropped or dislodged from the stand must be picked up and replaced by the rider.

GOLF BALL AND SPOON RACE

Required Equipment:

- Three bending poles, placed 24-30' apart
- One plastic paint bucket
- Three golf balls
- One long-handled spoon (with a 1" strip of brightly colored tape on handle where it meets the bowl)

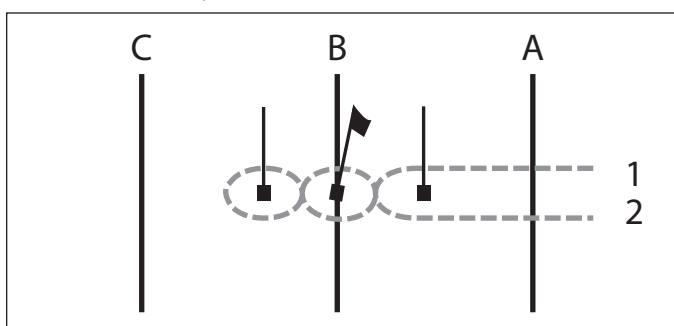

DETAIL: The bending poles will be placed 24' to 30' apart, midway between lines A and C. On the center pole will be fixed a container in which are placed two spare golf balls. The first rider of each team will carry the spoon on which the golf ball is placed. On the signal to start, rider number one will cross line A, ride down the line of bending poles passing them on alternate sides, turn around the last pole and return in the same manner, crossing line A. Rider number one will hand the spoon and golf ball to rider number two, the golf ball still being untouched by hand. Rider number two completes the course in the same manner. The winning team will be the team whose second rider crosses the finish line first, carrying the golf ball on the spoon.

The golf ball must not be touched by hand except when being picked up or while mounting.

Should the golf ball be dropped, the rider must either pick it up or collect another one from the bucket attached to the center pole, and resume the course again from the point where the golf ball was dropped. The golf ball need not be placed on the spoon until this point is reached.

SECTION III: Competition

The spoon may not be held or touched in the area marked by the brightly colored tape except while mounting. If dropped at a handover, the golf ball and/or spoon may be retrieved by either rider, mounted or unmounted, and placed on the spoon of the next rider to go.

HI-LO RACE

Required Equipment:

Two 18" traffic cones

Three tennis balls

One 7' pole with 8" steel ring with net or bag attached

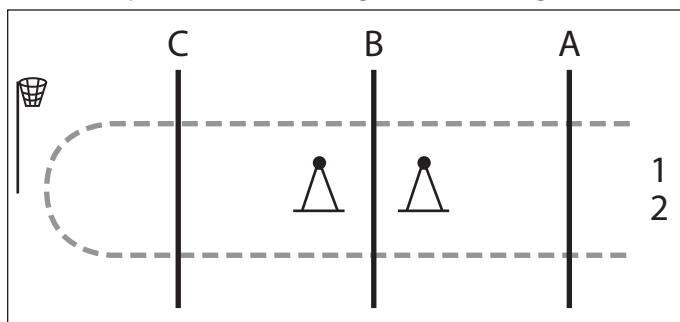

DETAIL: The 18" traffic cones will be 24' to 30' apart; a tennis ball will be placed on the top of each traffic cone. Three yards beyond line C, there will be a pole with an 8" diameter steel ring, 7' from the ground, with a net or bag attached to the ring. A volunteer will hold the post.

The ball **MUST** be placed in the net or bag while mounted.

Rider number one will carry a tennis ball and place it in the net or bag and upon returning down the arena, collect a ball from the top of one of the cones closest to C and pass it to the next rider. Rider two completes the course in the same manner, with rider #2 picking up the ball on the cone closest to A. The winning team will be the team whose second rider crosses the finish line first, mounted, carrying a tennis ball.

HOUSEWIFE'S SCURRY

Required Equipment per team:

One heavy-duty plastic trash bin, or similar, 23-27" high, approximately 19" in diameter, with plywood circle bolted to bottom.

One plastic paint bucket

One 5-gallon water bucket

One potato, one carrot, one onion (plastic vegetables may be used)

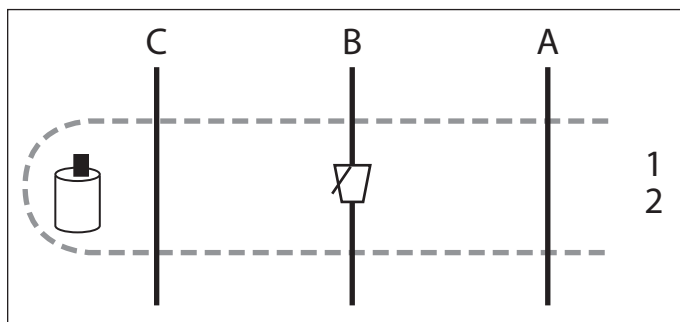

DETAIL: Place the trash bin 3 yards beyond the changeover line. On top of the bin, place the plastic paint bucket containing one carrot and one onion. The potato is given to the first rider.

On the signal to start, rider number one crosses the start line carrying a potato, rides to their team's bucket (on line B) and drops the potato in. This rider continues over the changeover line, takes the carrot from the team's container, rides over line A for the handoff to rider number two. The second rider completes the course in the same manner collecting the onion. The second rider will drop the onion into the team's bucket on the way back (double dunk) to the finish line. The winning team will be the team whose second rider is across the start/finish line, with nothing left in their hand.

Should a rider collect and drop the wrong article into the bucket and not correct the error, the team will be eliminated.

Should the bucket containing the vegetables be knocked over but remain on top of the bin, it must be placed upright even if it is empty. This may be done mounted or unmounted.

HULA-HOOP RACE

Required Equipment:

One hula-hoop, at least 28" in diameter

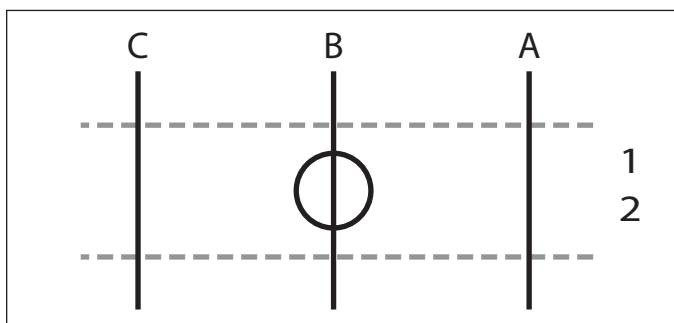

DETAIL: This race is ridden in pairs. A hula-hoop at least 28" in diameter for each team will be placed on the centerline. Riders one and two at the start line will ride to the hoop, rider number one dismounts and goes through the hoop while rider number two holds the mount. Rider number one remounts and the pair rides on to the changeover line. Both riders again ride to the hoop, where rider number two goes through the hoop while rider number one holds rider number two's mount. Rider number two remounts and both ride to and across the finish line. The winning team will be that with both riders first crossing the finish line mounted.

At the changeover, all eight mount legs must cross over the line before any return to the playing field. The rider who is to hold the mount at the hoop, does so by grasping the rein. Their partner may not touch the hoop until they have handed over the mount.

SECTION III: Competition

HURDLE RACE

Required Equipment:

Two hurdles, 30 inches wide, 1 ft. high

Two hurdles, 30 inches wide, 2 ft. high

Two mugs, half full of water

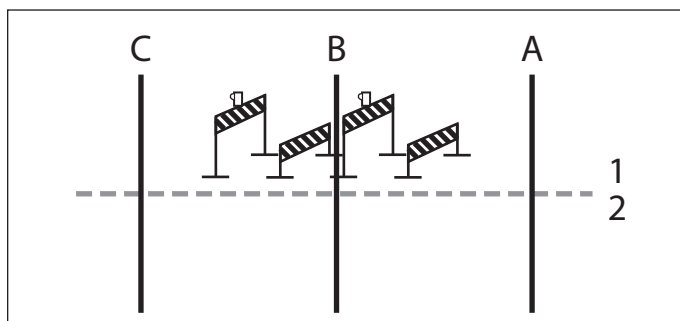

DETAIL: Four hurdles will be placed 6 ft. apart centered between lines A and C. They will be alternately 1 ft. and 2 ft. high, beginning with 1ft. closest to line A. A mug, 1/2 full of water, will be placed on the center of the 2 ft. high hurdles. This race is ridden in pairs. Riders one and two will stand side by side at the start line.

On the signal to start, riders number one and two will ride forward to the hurdles, where rider one will dismount and hand the mount to rider two. Rider one will then step over the first hurdle, crawl under the second hurdle, go over the third hurdle and under the fourth. Rider one will then remount and both riders will ride to the changeover line.

After crossing the line, the riders will turn around to cross the field again, this time rider two will dismount and go under and over the hurdles with rider one holding rider two's mount. Rider two then remounts and both riders ride to the start/finish line.

The winning team will be the one who is first across the finish line, mounted, on their mounts. At the changeover, all eight mount legs must cross over the line before any return to the playing field. The rider holding the mount at the hurdles may grasp its rein before, or as they ride down the arena.

Should any hurdle be knocked over, or a mug fall off, the rider concerned must replace them and re-negotiate all the hurdles again.

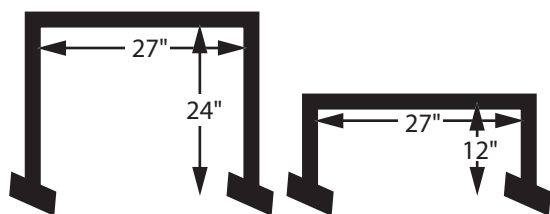

LITTER RACE

Required Equipment:

One round plastic laundry basket

One 4' wooden dowel 1/2" in diameter

Two 1-quart cardboard milk cartons (litter) with the top (pouring end) cut off for a length of 7-3/4" OR two rounded plastic cartons (approximately same length as cardboard cartons)

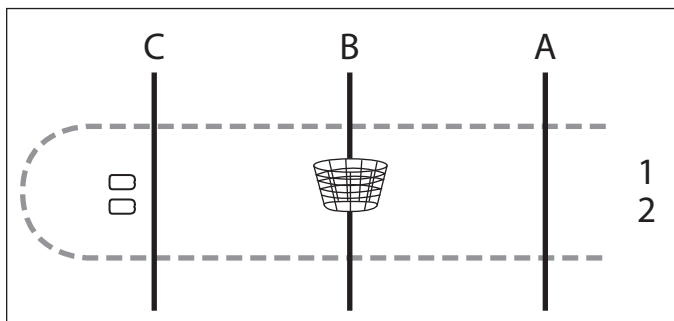

DETAIL: 3 yards behind line C, two cartons will be placed on the ground, the open ends will face away from line A. A laundry basket will be placed on line B for each team. Rider number one will ride to the far end; pick up a carton on their dowel and return to dump it into the basket. They will then continue back to the start and hand the dowel to rider number two. Rider two will similarly cross the changeover line, pick up a piece of litter and put it into the basket. The winning team will be the team whose rider number two first crosses the finish line, mounted and carrying the dowel.

REMEMBER—Once a rider has selected their "litter," that is the ONLY litter they may pursue. If the litter chosen has been previously kicked over the changeover line into the playing field by a previous mount, the rider may pick it up in the playing field but must then carry it back over the changeover line and then return to the playing field to complete the round. All four feet of all mounts must cross the changeover line regardless of where the litter is located.

The riders must remain mounted and must not hold the litter by the hand when picking it up, carrying it on the dowel, or when dumping it. If the carton is smashed and can't be picked up, a rider may dismount to repair it, but must remount to pick it up on their dowel. Cartons may be weighted with sand if it is windy. Should the basket be knocked over, the rider concerned must set it up again, and replace all the litter in the basket, including their own, and proceed.

SECTION III: Competition

MUG SHUFFLE

Required Equipment:

Four bending poles, placed 24-30' apart

Two 12 oz. mugs—plastic, enamel or stainless steel recommended, with or without handles

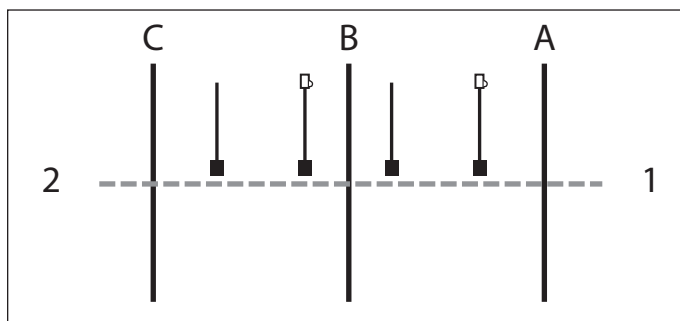

DETAIL: Four bending poles will be placed 24 to 30' apart centered between lines A and C. One mug is placed on top of pole 1, closest to line A; the second mug is placed on top of pole 3. Rider number one will be behind line A. Rider two will be behind line C.

On the signal to start, rider number one rides to pole 1 and moves the mug to pole 2, then moves the mug from pole 3 to pole 4. Rider number two completes the course in the same manner. The winning team will be the one whose rider number two crosses the finish line first.

Dropped mugs must be placed on the correct pole before proceeding. Poles which are knocked over must be reset before proceeding. An attempt must be made to put the mug on the pole while mounted.

NEEDLE & THREAD RACE

Required Equipment:

Needle (wooden dowel, 10" long, 1-inch diameter with four (1/2 inch) holes drilled, starting one inch from the end allowing 1/2 inch between each hole.) The needle must be taped (with 2-inch masking tape) to a bending pole placed on line B. The pole should be a bending pole.

Thread (2 pieces) 18" cotton shoestrings, knotted at one end, wrapped with 2" of tape on the opposite end.

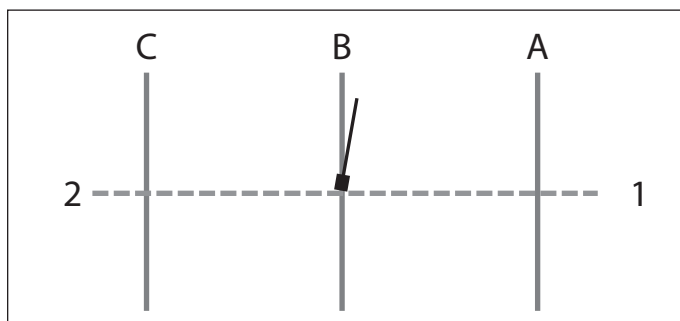

DETAIL: First rider of each team is mounted and located behind line A, carrying a thread. The second rider is mounted and carrying a thread behind line C. On the signal to start, the first rider on each team rides to the bending pole on line B;

threads the needle and gallops on, crossing line C. The second rider complete the course. The winning team will be the team whose second rider is first to cross the finish line mounted and whose team has successfully threaded the needle two times. A successfully threaded needle means that the thread ends must be on each side of the needle—folding or bunching the thread is not allowed.

SPECIAL RULES: Each rider must thread the needle while mounted. If any previous threads are dislodged before the rider threads the needle, the rider may replace them mounted or unmounted.

If a bending pole is knocked over, the rider must reset the pole and replace the threads already placed by previous riders, mounted or unmounted. The rider must then proceed to thread the needle while mounted. If the pole is knocked over after the rider has successfully threaded the needle, the rider must reset the pole and rethread all dislodged threads either while mounted or unmounted.

OLD SOCK RACE

Required Equipment:

One 5-gallon water bucket

Three old socks (rolled up and sewn into a ball the size of a fist)

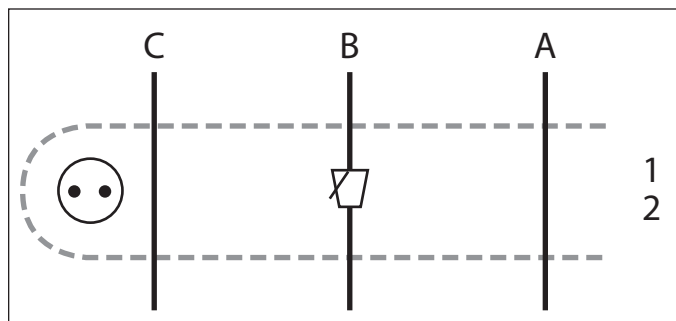

DETAIL: Place the water bucket on line B. If desired, draw or paint a 24" circle three yards behind the changeover line and place two of the socks in the circle, the third sock will be given to rider number one. On the signal to start, rider number one, carrying a sock, rides to the bucket on line B and drops the sock into it. The rider then continues to the far end to pick up a sock. The rider must dismount to pick up a sock and may dismount at any time after they have successfully dropped the sock into the bucket, but the rider and all four feet of the mount must cross line C (either mounted or unmounted) before returning for the handover regardless of where the sock was picked up. Rider number two completes the course in the same manner, dropping the last sock into the bucket (double dunking) on the way back. The winning team will be the team whose rider number two is first over the finish line mounted. If the socks are knocked out of the circle, they need not be placed back in.

SECTION III: Competition

PONY CLUB RACE

Required Equipment:

One heavy-duty plastic trash bin, or similar, 23-27" high, approximately 19" in diameter, with plywood circle bolted to bottom.

Eight letters—at least 8" by 8" and ¼ inch thick with a hole in the center top for hanging. The letters should be painted at least 5 inches tall.

One post, 7' high, with two cross bars, each with four hooks for hanging the letters

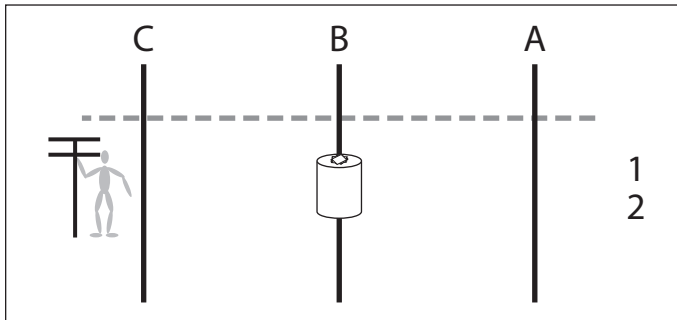

DETAIL: The trash bin is placed on line B, and on top of the bin are four letters, spelling mount, in random order. The letters should be shuffled and stacked on top of the bin in pairs. One pair should be stacked diagonally on top of the other pair of letters. The other four letters, spelling club, will be hung on a post approximately 7' high, which has two cross bars each with four hooks screwed to the lower edges, behind the changeover line, about halfway to the 6-yard line.

A volunteer will hold the post.

On the signal to start, rider number one rides to the bin and picks up any two letters, rides to the volunteer and hangs the letters on the hooks in the correct spelling order before returning to the start/finish line. NOTE: The letters are written on both sides so that the final spelling is correct when observed from either side.

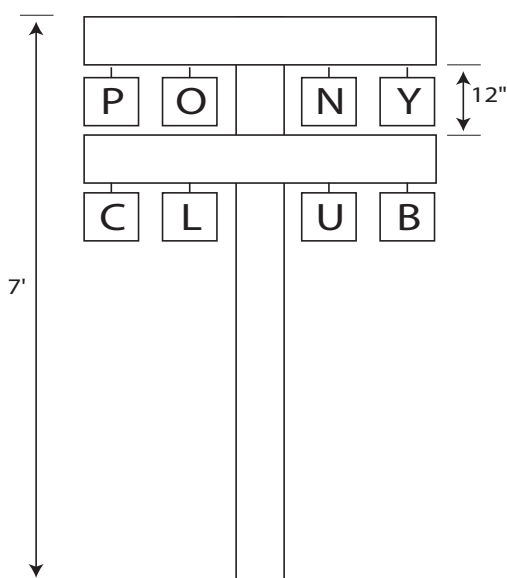

Rider two does likewise, hanging the remaining two letters. The winning team is the first team with all the letters on the hooks in the correct spelling and with rider number two crossing line A mounted. The volunteer may not help at any time and merely holds the post.

Letters dropped in attempting to hang them on the hooks may be picked up by dismounting. The rider must remount and then place the letters when mounted. Provided they have been correctly hung, letters blown off in the course of the race do not need to be replaced.

Letters placed in the wrong order must be corrected by the rider who placed the letter or letters. If the error is not noted until the next rider has placed their letters, the rider must retrace their actions back to the rider who made the error to be corrected and re-start from that point.

PONY EXPRESS

Required Equipment:

Four bending poles

Two weighted envelopes

One large pillowcase

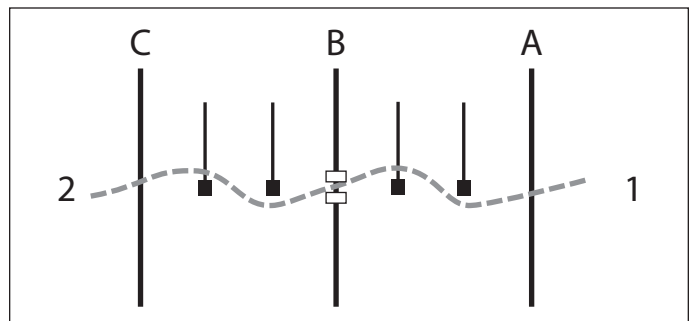

DETAIL: The bending poles will be set in a straight line, two on each side of line B, 24 to 30 feet from line B. The remaining two poles should be set 24 to 30 feet, one on either side of the first two poles. Refer to diagram. The two weighted envelopes will be placed on the ground at line B. Rider number one will be mounted behind line A. Rider number two will be mounted behind the changeover line. Rider number one will be given a pillowcase.

At the signal to start, they will ride down, weaving through the bending poles, to line B, where they will dismount, pick up an envelope, put it in the pillowcase before remounting, mount, and weave the remaining poles keeping the same pattern. The rider must be mounted passing the second bending pole, and must have remounted prior to passing the third bending pole. Upon crossing the changeover line, rider number one will handoff the pillowcase to rider number two. Rider two will complete the course in the same manner. The winning team will be the team whose second rider crosses the finish line first, carrying the pillowcase containing two envelopes.

SECTION III: Competition

POSTMAN'S CHASE

Required Equipment:

Five bending poles, placed 24-30' apart

Two weighted envelopes

One large pillowcase

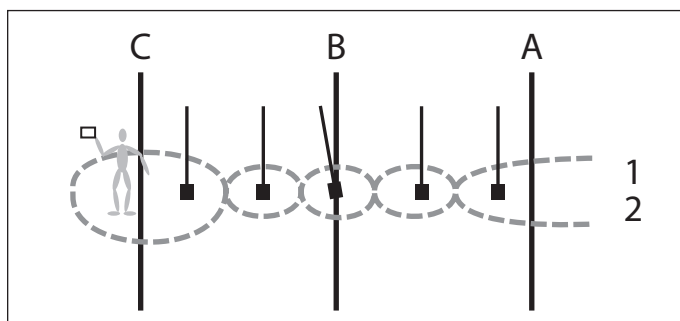

DETAIL: Five bending poles will be placed 24' to 30' apart, midway between lines A and C. (Same as setup for Bending Race.) A volunteer will stand holding the two letters, 3 yards beyond the changeover line. On the signal to start, rider number one carrying a pillowcase will weave through the bending poles, and across the changeover line, where the volunteer will hand them a letter. The first rider will place the letter in their pillowcase before re-crossing the changeover line, returning by weaving through the bending poles past line A, where they will hand the pillowcase to rider number two. The second rider will similarly collect the remaining letter from the volunteer. The winning team will be the team whose second rider is first over the finish line, mounted and with both letters in the pillowcase.

The volunteer must remain beyond the changeover line during the entire game. The volunteer may assist by holding the inside rein of the rider only while rider places letter in the pillowcase.

POTATO RACE

Required Equipment:

Three potatoes

One 5-gallon water bucket

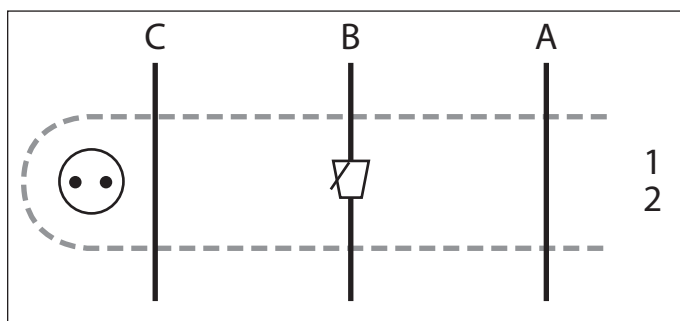

DETAIL: 3 yards behind the changeover line there will be two potatoes for each team, within a 24" diameter circle for visibility if desired. On the centerline place the 5-gallon bucket.

On the signal to start, rider number one, carrying a potato, will ride to their team's bucket and drop the potato into it.

The rider then continues to the far end to pick up a potato. The rider must dismount to pick up a potato and may dismount at any time after they have successfully dropped the potato into the bucket, but the rider and all four feet of the mount must cross line C (either mounted or unmounted) before returning for the handover regardless of where the potato was picked up.

Rider two completes the course in the same manner, dropping the third potato in the bucket on the way back (double dunking). If the potatoes are knocked out of the circle, they need not be placed back in.

PYRAMID RACE

Required Equipment:

Two heavy duty plastic trash bins, or similar, 23-27" high, approximately 19" in diameter, with plywood circle bolted to bottom.

Four plastic containers approximately 7" square and 3 3/4" deep partially filled with sand or sawdust to weigh 1 lb or more.

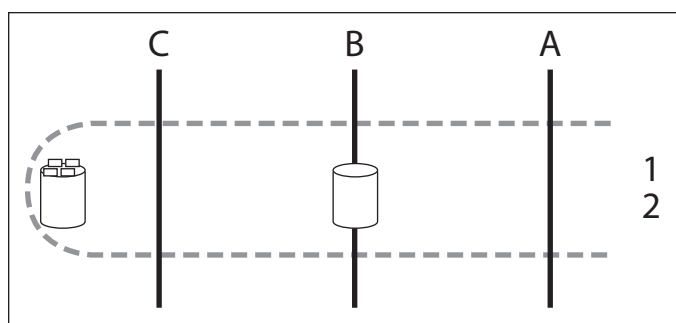

DETAIL: There will be a trash bin on the center line and the second bin three yards beyond the changeover line. There will be four plastic containers placed on the bin beyond the changeover line.

On the signal to start, rider number one will ride to the changeover line and collect a container which will then be placed on the bin on the center line. Rider one then either returns to the second bin to collect a second container and stacks it on the first OR proceeds to the start/finish line. The remaining containers are collected singly by either rider, provided that each collects at least one container. The winning team will be the one whose rider two is first over the finish line, with all four cartons stacked on the center line bin.

HINT: Rubbermaid plastic "Seal 'n Saver" container number 5168 (2 qt./1.9 liter) fits size requirements and these are available at discount stores and grocery stores. Lids fit very tight but use duct tape or electrical tape for added security.

SECTION III: Competition

QUOITS & CONE

Required Equipment:

- Two plastic or rubber quoits/rings, approximately 6" in diameter, with at least 4" opening
- One tennis ball
- One 18" traffic cone

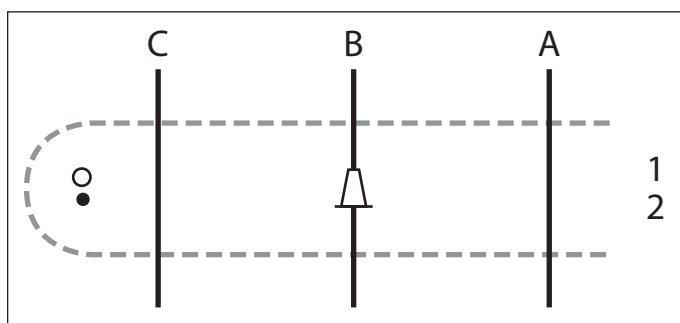

DETAILS: Three rubber quoits and a tennis ball for each team will be placed within a marked ring 3 yards behind line C. A cone will be placed 15' from line A.

Rider number one, carrying a quoit, rides to the cone, places the quoit over the cone, continues to line C, picks up a quoit, returns to line A and hands it off to rider number two. Rider number two places the quoit over the cone, continues to line C, picks up the tennis ball and places the ball on the cone on the way back to the finish line. With two quoits and a tennis ball on the cone, the winning team will be the one whose rider number two is first over the finish line.

RING RACE

Required Equipment:

- Two bending poles with ring holders
- Three round rubber rings (Hoover drive belts 4" in diameter)

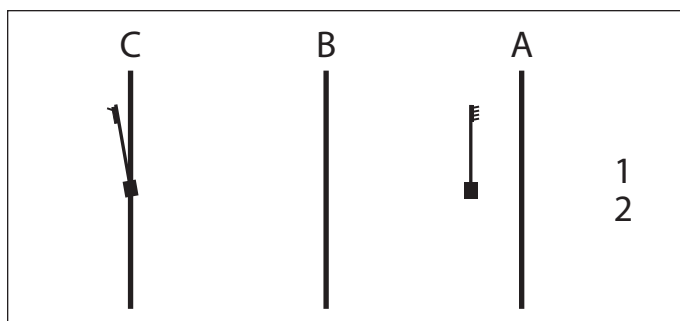

DETAIL: One bending pole is placed 15 yards from line A with a ring holder (2" x 2" x 20" piece of wood in which four sections of 1/2" wooden dowel, 3" long, have been set and glued at 5" intervals) securely taped on with masking tape. The four-ring holder is to face line A. On the four-ring holder, two rings should be hung on the center two dowels. The second pole will be placed at line C with a single ring holder (2" x 2" x 10", 1/2" dowel, 6" long at center) taped on. The single ring holder is to face away from the starting line (line A). The rings may be painted a bright color for visibility.

Rider number one, carrying a ring, will ride to the far end of the arena and hang their ring on the dowel. Then rider number one rides back, collecting a ring from the pole near line A and hands the ring to the rider number two. Rider two completes the course in the same manner, carrying the last ring over the finish line.

Should the ring be dropped or knocked off the ring holder dowel (line A), the rider must dismount, replace the ring, remount and take the ring from the dowel while mounted.

If a ring placed by a previous rider is knocked down in an attempt to place the ring on the dowel (line C), the rider must dismount and may replace that ring while unmounted. However, each rider must place their own ring while mounted. If either holder is knocked over, the rider must dismount and reset it. If the rider has not yet taken or placed a ring, they must remount to do so.

ROPE RACE

Required Equipment:

- Four bending poles, placed 24-30' apart
- 3' long rope (cotton preferred, at least 1/2" thick, no knots)

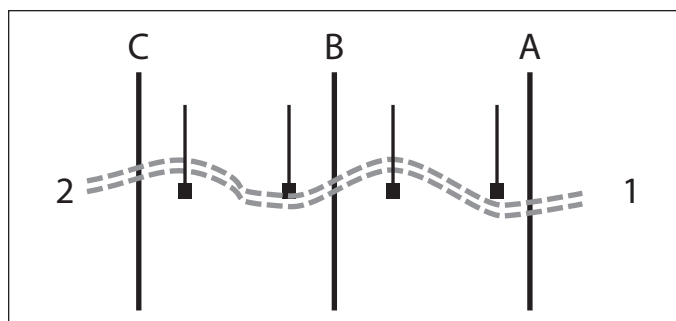

DETAIL: The bending poles are placed 24' to 30' apart midway between lines A and C. Rider number one will be behind line A. Rider two will be behind line C. Rider number one, carrying the rope rides down the line of bending poles passing them on alternate sides, crosses the changeover line where the second rider will grasp the other end of the rope. Both riders will then ride back weaving the bending poles, each rider holding one end of the rope, and crossing line A. The winning team will be the team whose riders one and two — each holding one end of the rope — have both crossed the finish line first.

The rope must be grasped behind lines A or C. No knots are permitted on either end of the rope.

NO HOLDING HANDS! The rider's grip must be on the rope.

SECTION III: Competition

RUBBER DUCKY

Required Equipment:

- One five gallon bucket $\frac{3}{4}$ full of water
- One three gallon bucket $\frac{3}{4}$ full of water
- One heavy duty plastic trash bin, or similar, 23-27" high, approximately 19" in diameter, with plywood circle bolted to bottom.
- One 3" rubber duck
- One large pillowcase

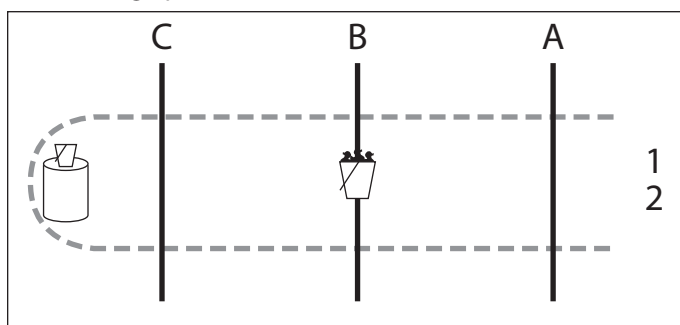

Detail: The five-gallon bucket with water and one duck is placed 15' from line A. The overturned bin is three yards beyond the changeover line. On top of the bin place the three-gallon bucket of water. Rider number 4 has the large pillowcase.

On the signal to start, rider number one rides to the five-gallon bucket and collects the duck. The rider continues over the changeover line and places the duck into the three-gallon bucket before returning to the start/finish line. Riders two, with the sack, rides to the changeover line, collects the duck from the three-gallon bucket, places it in the pillowcase, and returns to the finish line. The winning team will be the team whose second rider is across the finish line with the pillowcase with the duck inside.

At any time riders may collect ducks mounted or dismounted. Loss of water is not penalized. Riders who dismount to collect a duck from the first bucket, must remount before placing that duck into the three gallon barrel.

SPILLERS POLE RACE/PONY CLUB POLE RACE

Required Equipment:

- One bending pole
- Eight lettered cylinders made of 2" PVC pipe, 6" long. Each cylinder will have one of the letters from the word SPILLERS (or PONY CLUB) repeated 3 times on the surface

DETAIL: Three yards beyond the changeover line there will be eight lettered cylinders, with letters S,P,I,L,L,E,R and S (or P,O,N,Y,C,L,U,B) lined up in any order perpendicular to the changeover line. A bending pole (the Spillers or Pony Club Pole) will be on the center line of the arena. Rider number one will begin with a cylinder lettered "S" (or "B").

On the signal to start, rider number one will ride forward to the Spiller's or Pony Club pole (bending pole) and slot the

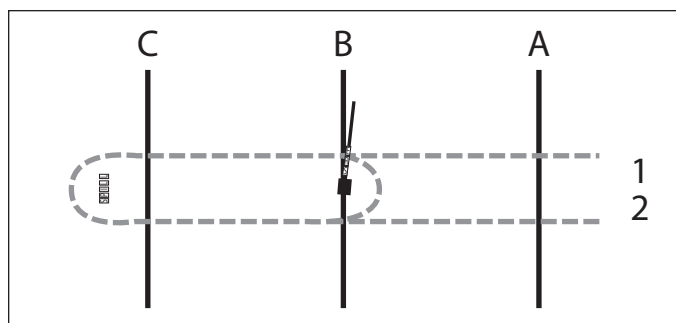

cylinder over the pole. Rider one continues to the far end, dismounts and collects the letter "R" (or "U"). They remount and return to the center where they slot the "R" (or "U") onto the pole. They then return to the far end, dismount and collect carton "E" (or "L"), remounts and rides to the start/finish line to hand cylinder "E" (or "L") to rider two. Riders repeat the process until the word "SPILLERS" (or PONY CLUB) can be read from the top to the bottom of the pole. Rider two slots the final "S" (or "P") over the pole on their way back and crosses the finish line. The winning team will be the one whose rider four is first over the finish line, with the word "SPILLERS" (or PONY CLUB) spelled correctly from the top to the bottom of the pole. The rider and all four feet of the mount must cross line C (either mounted or unmounted) before returning, regardless of where the cylinder was picked up.

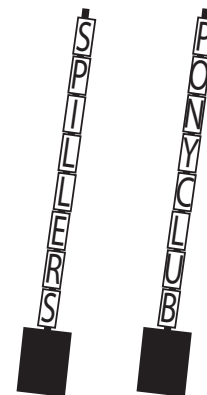

Letters placed in the wrong order must be corrected by the rider who placed the letter or letters. If the error is not noted until subsequent riders have placed their letters, the subsequent riders must retrace their actions back to the rider who made the error to be corrected and re-start from that point.

Cylinders placed in the wrong order, or with the letter upside down, must be corrected by the rider who placed the cylinder incorrectly.

Cylinders placed in the wrong order, or with the letter upside down, must be corrected by the rider who placed the cylinder incorrectly.

STEPPING-STONE DASH

Required Equipment:

- Six stepping stones

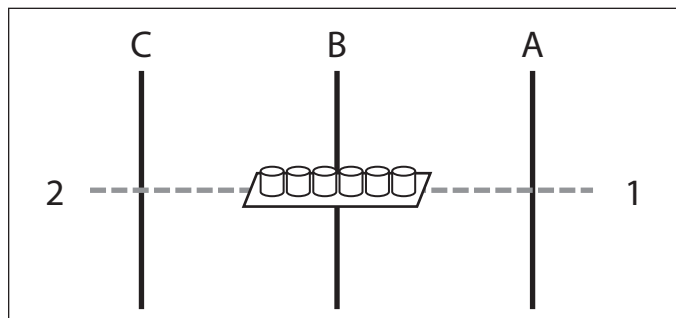

SECTION III: Competition

One Board 1" x 8" x 8'-10' (Optional)

DETAIL: Six stepping stones (each stone is a one-gallon paint can filled with concrete, set upside-down) placed one upside-down bucket's width apart, midway between lines A and C. Rider number one will be mounted behind line A; rider number two will be mounted behind the changeover line. On the signal to start, rider number one will ride to the stepping stones, dismount, and dash across (on top of) the stones while leading the mount, beginning with the stone closest to the rider's starting line and ending with the stone farthest from the rider's starting line, treading on each stepping stone and on the ground after the last. They will then remount before riding across the changeover line. Rider two similarly completes the course. The winning team will be the team whose rider number two is first over the finish line, mounted. If a stone is missed, knocked over by a rider or a mount's foot, or the rider's foot hits the ground before the last stone is treading, rider must reset the stone and redo all six stones.

No competitor is allowed to get help from the mount or its tack by holding onto the mane, the neck, the saddle, or any part of the bridle held close to the bit (leaning on the bridle for support).

STICK PEGGING RELAY

Required Equipment:

One heavy duty plastic trash bin, 23-27" high

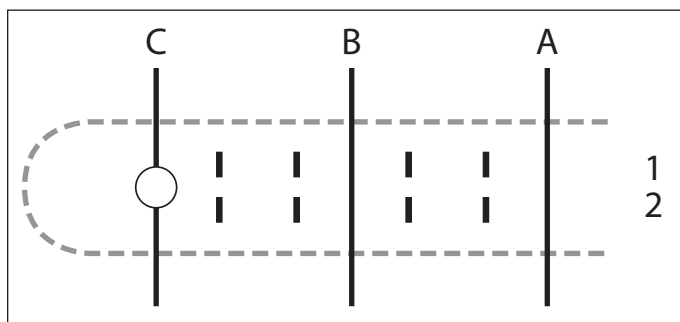

One wooden or plastic 4' dowel, 1/2"—3/4" in diameter), rounded at both ends
Eight 6" tall pieces of 2"x4" wood

DETAIL: Plastic bin sits on line C. The eight wooden blocks, standing on end, will be placed in two lines (4 per line), 6-1/2 feet apart (width). Starting out from line B, the second and third blocks will be 3-1/2 feet from line B. From the second to first and third to fourth, the length will be 6-1/2 feet between blocks.

Rider number one, with stick held in right hand, rides down the left side of the lane (on rider's right), knocks down the first and second block in the left hand row with the stick, continues and makes a right hand turn around the end bin, returns down the right side of the lane, knocks down the first and second block of that row, continues to line A and passes the stick to rider number two, right hand to right hand. Rider number two completes the course in the same manner,

knocking down the next two blocks on each side. The winning team is the one with the first rider number two crossing the finish line, stick in hand.

If a horse knocks down a block, the rider must replace it before continuing. If a rider knocks down a wrong block, it must be replaced before continuing.

SWORD RACE

Required Equipment:

Two bending poles, placed 24-30' apart

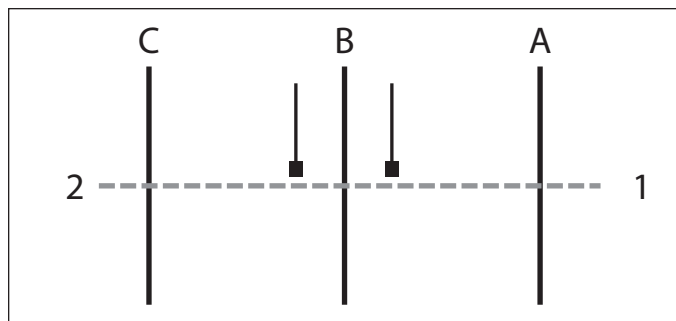

Two rubber rings (Hoover drive belt 4" in diameter OR 4" interior diameter plastic rings) fastened to poles with rubber bands
One sword

DETAIL: The bending poles are placed 24' to 30' apart. The sword is a 2' wooden (blunt), 1/2" diameter dowel, with a 1' piece of 1/2"-diameter dowel taped at a right angle about 6" from one end. The sword may be made by notching handle and blade so they mesh for better fit.

Rider number two is mounted behind the line C. Rider number one, carrying the sword, will ride to one of the poles, pick up the ring on the sword, ride over line C and hand over the sword to rider number two. At no time may the sword be touched on the blade side of the crosspiece. Rider two completes the course in the same manner. When rider number two crosses the finish line mounted, they must have both rings on the sword.

If a ring is dropped, the rider may retrieve it mounted or unmounted. If unmounted, the rider may replace it by hand on the sword and hold it until remounted and returned to where it was dropped, where the rider must let go of the ring to resume the race. The rings may not be touched by hand, and the sword may not be touched above the crosspiece, except when correcting an error.

The rider may ride straight and need not weave through the poles. If a pole is knocked over, it need not be reset. If the ring is still attached to the downed pole, it may be collected either mounted or unmounted, using the sword or the hand.

Please note: The equipment crew may prefer to set up the lane as in the Novice and Junior divisions with all four poles. If so, the rings should be placed on the center two poles.

SECTION III: Competition

TACK SHOP RACE

Required Equipment:

Two heavy duty plastic trash bins, or similar, 23-27" high, approximately 19" in diameter, with plywood circle bolted to bottom.

One bending pole topped with a "money box", 6" diameter plastic container with sides no taller than 1½" which are vertical or angled out slightly with dowel rod attached to fit down into bending pole

One plastic grooming tray

One coin—4" in diameter, plywood or stiff material

Two pieces of tack: sponge, dandy brush, comb, rubber curry comb, or other such suitable items

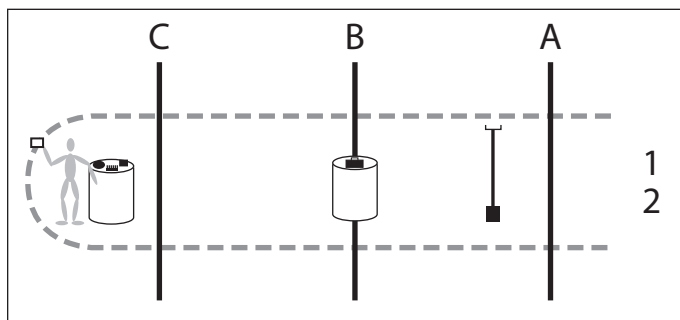

DETAIL: One bending pole topped with the "money box" will be placed fifteen yards from the start line. Fifteen yards from the changeover line will be one trash bin with a plastic grooming tray on top. A volunteer begins standing behind a trash bin placed three yards beyond line C with 2 tack items lying on the trash bin. Rider number one will start carrying the coin.

On the signal to start, rider number one will ride forward to the "money box" on the bending pole and deposit the "coin." Rider one continues to collect the grooming tray by the handle and then rides to the volunteer who puts any one of the items in the grooming tray. Rider one then returns the grooming tray to the first bin. They then ride to the money box, collect the coin and hands it to rider two. Rider number two repeats the process. The winning team will be the one whose rider two is first over the finish line carrying the coin.

If an item is dropped behind the changeover line, either the rider or the volunteer may pick it up. The item must be in the tray before the rider re-crosses the changeover line. The volunteer may hold the rein of the mount behind the changeover line.

Weights may be placed in the tack box in windy conditions. In such cases, the weights are considered to be part of the equipment and must be replaced if the tack box is knocked over. Grooming tray must be carried by the handle.

HINT: For the money box we found a 6" drainage tile internal plug was inexpensive and easy to attach to a 1" dowel rod with a screw. The dowel fits nicely inside the PVC bending pole. For the coin, a 4" cork coaster for works well and can be found in most housewares departments. Avoid tack items with sharp edges such as hoof picks or metal curry combs.

THREE CONE

Required Equipment:

Three traffic cones, 18" high

Three tennis balls

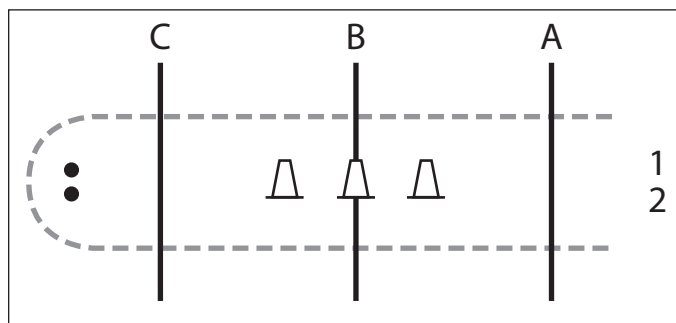

DETAIL: Three cones will be placed 24-30' apart, centered between lines A and C, with the number one cone being closest to line A. Two tennis balls will be placed 3 yards behind line C (within a ring marked on the ground). One ball is given to the first rider.

On the signal to start, rider number one, carrying a ball, rides and places the ball on cone two. They ride to the far end, dismounts, picks up a ball, remounts and returns to hand the ball to rider number two. Rider number two places the ball on cone three, picks up the last ball then places the last ball on cone one before crossing the finish line. The winning team will be the one whose second rider crosses the finish line first with all three balls on all three cones.

THREE-FLAG RACE

Required Equipment:

Two 18" traffic cones, cut down to leave 4" diameter opening (same as Two Flag cones)

Three flags, 4' long

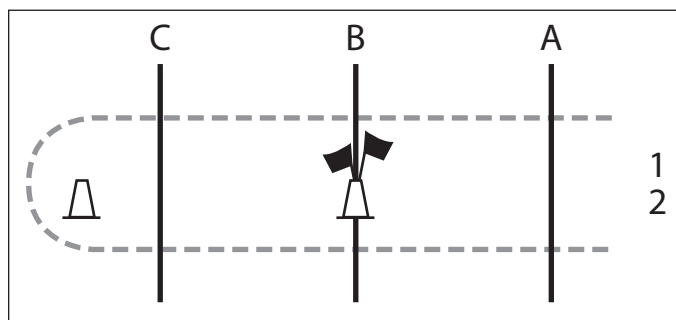

DETAIL: Place one cone 3 yards behind line C. A second cone will be placed on line B with two flags placed in it. One flag is given to the first rider. (A flag consists of the following: 4' wooden dowel, 1/2" diameter, a piece of cloth 6" x 8" attached to one end of each of the dowels.)

On the signal to start, rider number one will ride to the other end of the arena and place the flag they are carrying in the holder there. They will ride back, picking a flag out of the team's holder on line B and hand this flag to rider number two behind the start line. Rider completes the course in the same manner so that at the end, the team will have placed

SECTION III: Competition

two flags in the holder at the far end of the arena and rider number two finishes over the start line mounted and carrying the third flag. Should any rider take more than one flag from the holder, they must replace the surplus. A flag not in possession of the rider, (e.g., those that have fallen out of the holder), must be picked up and returned to the holder, mounted or unmounted. If the flag is dropped while an attempt has been made to place the flag in the holder while mounted, the flag may then be placed in the holder mounted or unmounted. Holders knocked over must be reset, either mounted or unmounted, by hand or by flag. If a flag should come off the cane, the stick may be used to complete the race. On windy days, rubber bands can be used to keep the flags furled and prevent them from blowing over.

THREE-LEGGED RACE

Required Equipment:

One feed sack

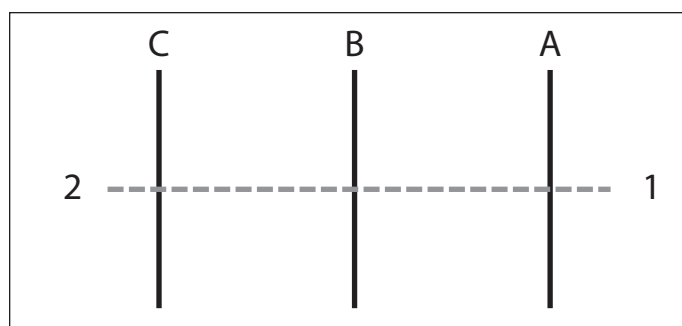

DETAIL: Rider number one will be mounted behind line A; rider two will be unmounted, holding their mount, standing behind the changeover line.

On the signal to start, rider number one carrying the sack rides to the changeover line where they pass the sack to rider two and dismounts. Riders one and two place one foot each in the sack before crossing line C, then proceed to line A leading their mounts. The winning team will be the one whose riders, each with one foot in the sack, leading their mounts, cross the finish line first. All twelve legs must cross the finish line to complete the race.

Rider one may dismount any time after crossing line A but rider and mount must cross the changeover line before getting into the sack.

Rider one may pass the sack to rider two before crossing the changeover line if they wish.

The sack must remain above the knees when running.

Riders and mounts must be behind the line before moving off in the sack and at the changeover between riders one and two.

THREE-MUG RACE

Required Equipment:

Four bending poles, placed 24-30' apart

Three 12-14 oz plastic, enamel or stainless-steel mugs, with or without handles, placed inverted on the first three poles

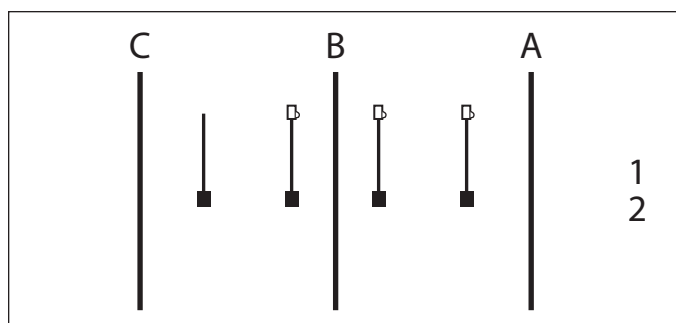

DETAIL: On the signal to start, rider number one goes forward to move the mugs from post to post in the following order: Mug from post three to post four; mug from post two to post three; mug from post one to post two, after which they return and crosses line A. Rider number two then moves the mugs back from post two to post one; from post three to post two; and from post four to post three, after which they cross line A. The winning team will be the team whose number two rider is the first over the finish line, mounted. If knocked over, poles must be reset.

THREE MUG RELAY

Required Equipment:

Three bending poles, placed 24-30' apart

One heavy-duty plastic trash bin, or similar, 23-27" high, approximately 19" in diameter, with plywood circle bolted to bottom.

Three 12-14 oz. plastic, enamel or stainless mugs with or without handles

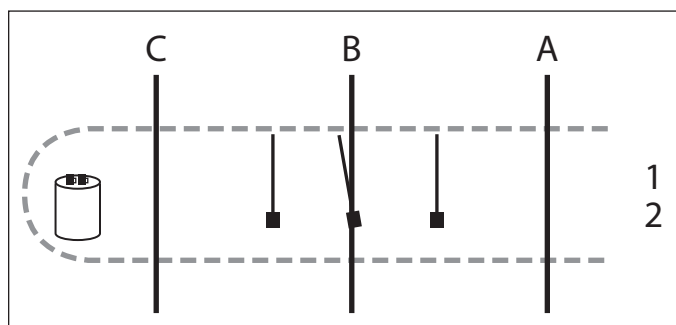

DETAIL: The bending poles will be placed 24 to 30' apart centered on line B. For the purposes of this race, pole #1 will be the pole closest to line A. The trash bin will be placed 3 yards behind the changeover line, in line with the bending poles. Two mugs, placed upside down, will be put on the trash bin; rider number one at the start will carry the third mug.

On the signal to start, rider number one will go to one of the team's poles and place the mug, inverted on the top, on any

SECTION III: Competition

pole other than pole #1. They will then go on to the bin, pick up another mug and return to handoff to rider number two, waiting behind line A. Rider two completes the course in the same manner placing the last mug, inverted, on pole #1 on the way back to the finish line. The winning team will be the team whose rider number two is first over the finish line, mounted with a mug placed on each of the team's five poles.

Riders ride straight and do not bend through the poles. Any mugs knocked off the bin must always be replaced upside down.

TOOL BOX RACE

Required Equipment:

One heavy duty plastic trash bin, or similar, 23-27" high, approximately 19" in diameter, with plywood circle bolted to bottom.

One plastic grooming tray

Two plastic or wooden toy tools

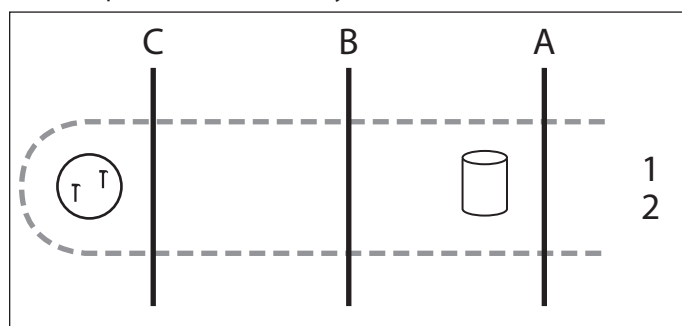

DETAIL: One trash bin will be placed fifteen yards from the start line. Three yards beyond line C will be two plastic or wooden tools, which may be placed within a 24" diameter painted circle, for visibility, if desired. Rider number one will start carrying the tool box.

On the signal to start, rider number one carrying the tool box will ride forward to the bin and place the tool box on the bin. Rider one then continues to the far end of the arena, dismounts, collects a tool, remounts and returns to place the tool in the tool box before crossing the start/finish line. Rider number two repeats the process, collecting the tool box by the handle and carrying it across the start/finish line.

Rider two must place the tool in the tool box before picking the tool box up to cross the finish line.

The tool box must be carried by the handle when crossing the start/finish line.

Weights may be placed in the tool box in windy conditions. In such cases, the weights are considered to be part of the equipment and must be replaced if the tool box is knocked over.

TWO-FLAG RACE

Required Equipment:

Two 18" traffic cones, cut down to leave 4" diameter opening

Two flags, 3' long

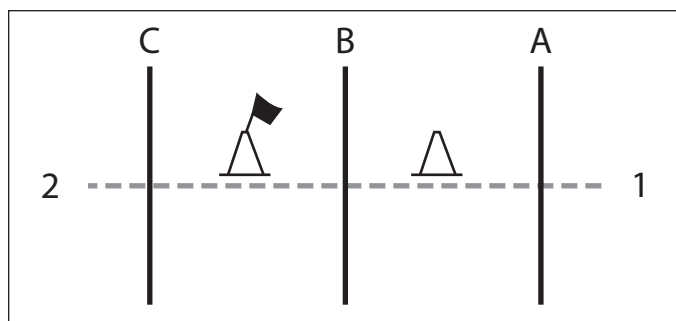

DETAIL: The poly-vinyl traffic cones are 18" high, with square platform base. The top of the cone is to be cut off, so that the inside diameter at the top is 4." The flags are 3' wooden dowels, 1/2" in diameter, with a piece of cloth 6" x 8" attached to one end of each dowel. The cones will be placed 15 yards from line A and 15 yards from the changeover line. In the holder nearest the changeover line one flag will be placed.

Rider number one will be mounted behind line A, rider number two will be mounted behind the changeover line. At the start rider number one, carrying a flag, will ride to the first cone and put their flag in it, then will ride to the second cone, remove the flag, and hand it over to rider number two. Rider two completes the course. The winning team will be the team whose rider number two is the first over the finish line, mounted and carrying a flag.

WINDSOR CASTLE RACE

Required Equipment:

One 26" traffic cone with turret holder in place

One 5-gallon water bucket 1/2 full of water

One turret

One orb (croquet, bocce ball or practice (plastic) polo ball spray-painted gold)

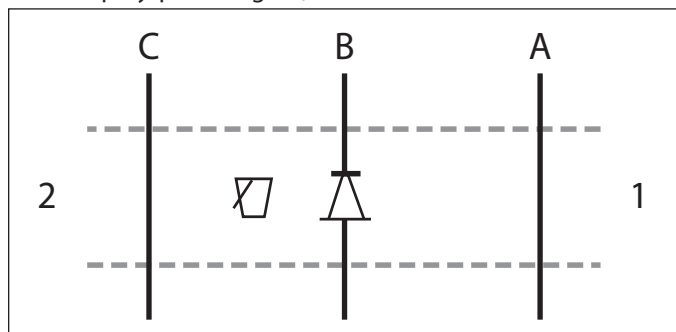

DETAIL: One traffic cone, representing the castle, with the turret and orb on top, will be placed on the centerline. The moat (water bucket) is placed midway between the center and changeover lines.

Rider number one is behind the start/finish line, and rider number two is behind the changeover line. Rider number

SECTION III: Competition

one carries the turret and rider number two carries the orb. On the signal to start, rider number one is the robber, who rides to the castle, steals the orb, and drops it into the moat (bucket) before going on to cross line C. Rider number two rescues the orb from the moat, replaces it on the turret and continues on to cross the finish line. The orb may be retrieved from the moat either mounted or unmounted. A reasonable attempt should be made to place or remove the orb or turret from the castle while mounted. In all instances, the rider must remount to continue the race.

The winning team is the team whose rider number two is first over the finish line, mounted, and having completed correctly all the phases of the race. The rider shall be mounted for all phases of the race, except as already specified for retrieving the orb out of the moat.

If the turret or the orb is dropped (or if the rider misses the moat when dropping the orb), they may be retrieved mounted or unmounted. If the turret or the castle is knocked over, it must be reset either mounted or unmounted.

WIZARD'S CASTLE

Required Equipment:

- 2 traffic cones 18" high
- 2 cones from a Flag Race 1 flag
- 1 sword
- 1 tennis ball

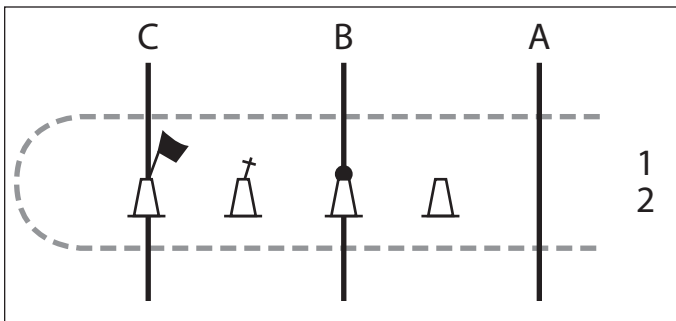

DETAIL: On line C there will be a cut-down cone with a flag. Midway between line C and line B a traffic cone will be placed with a sword. On line B, there will be a traffic cone with a tennis ball on top. The other cut-down cone will be placed midway between line A and line B.

On the signal to start rider number one rides to line C, removes the flag from the cone (the evil wizard's castle) and returns to place the flag in the pylon closest to line A. This is their own castle. Rider number one rides over the finish line. Rider number two takes the tennis ball (golden orb) from the cone on the centerline, and drops it into the center of the cone on line C (removing the golden orb takes away the evil wizard's power). Rider number two crosses the finish line. Rider number one takes the sword from the cone midway between lines B & C, returns to the finish line, and hands off the sword to rider number two. Rider number two plunges the sword into the center of the cone on line C (this will kill the evil wizard). The winning team will be the one whose rider number two crosses the finish line with a sword and orb in the wizard's castle, a flag in their own castle and all pylons remaining upright. The sword may not be touched above the crosspiece, except when correcting an error.

SECTION IV: Scoring

Article 53—Points and Penalties

Scoring for the Games will be on a positive point basis. The first place team in each game is awarded 1 point more than the number of teams competing in that game. The second place team is awarded one point less, etc. (e.g., If 6 teams compete, the 1st place team receives 7 points, 2nd place receives 6 points, 3rd place receives 5 points, 4th place receives 4 points, 5th place receives 3 points, 6th place receives 2 points.) An eliminated team receives one point. A disqualified team receives no points.

Article 54—Inquiries, Protests and Appeals

- Only competitors have the right to dispute scores and only competitors can participate in the process. Any non-competitor involvement in the process is considered unauthorized assistance.
- Competitors may only inquire about their team/individual scores.
- No protests of any sort concerning the playing of the Games, placement, elimination or disqualification shall be allowed in Games at any level. Upon penalty of disqualification, no competitor, parent, spectator, chaperone or other individual may approach the judges during the course of the Games to question their decision.
- Inquiries are encouraged if there are any scores with which the team does not agree or understand, or if they feel a mistake has occurred. Any disputes regarding scores are to be made following the procedures as stated in the governing documents.
- All inquiries, protests and appeals must be made in a polite and courteous manner. Abuse of these procedures or rude behavior may be penalized up to and including elimination and/or disqualification.
- The process will include verbal inquiry, written inquiry, written protest and written appeal, and use Appendix I.

Horse Management

Horse Management Verbal Inquiry

Verbal inquiries may be initiated if the team captain/individual competitor does not agree or **understand or if they feel a mistake has been made**. Horse management verbal inquiries are made to the CHMJ following the posting of scores.

Inquiries must be:

Initiated within 30 minutes from the time the score sheet(s) are posted by the CHMJ, and made in person by:

- The team captain, if competitor is on a team. The competitor involved may go with the team captain.
- The competitor involved (if competing as an individual).

If the team captain is riding when scores are posted and will not be available within the allowed thirty-minute period,

another team member may notify the CHMJ that an inquiry is likely.

At the end of the required 30 minute inquiry period, the CHMJ must:

- Make any necessary adjustments/changes to scores based on the outcome of any inquiries that may have been made and are settled. (Only the CHMJ may adjust points as a result of inquiries.)
- Transcribe any changes in scores to the HM master score sheet and turn in master score sheet to the rally scorer.
- No further inquiries will be permitted, except for transcription errors. Transcription errors are a discrepancy between actual scores shown on Horse Management sheets and scores posted by the scorer.

Horse Management Written Inquiry

Written inquiries may be initiated if the team captain/individual competitor disagrees with the CHMJ's decision on a verbal inquiry. Written inquiries are made to the technical delegate/steward via the rally office.

Written Inquiries must be:

Made in writing, using the official Horse Management written inquiry form (signed by the team captain/individual competitor), containing the references to the rules covering the reason for the inquiry Section VI, Chapter 24, D

Delivered within 30 minutes of the CHMJ decision on the verbal inquiry to the rally office.

Mounted Competition

Mounted Competition Scoring Written Inquiry

Written inquiries may be initiated if the team captain/individual competitor does not agree or **understand or if they feel a mistake has been made**. Mounted competition written inquiries are made to the technical delegate/steward following the posting of scores.

Inquiries must be:

Initiated within 30 minutes from the time the score sheet(s) are posted and made in person by:

- The team captain, if competitor is on a team. The competitor involved may go with the team captain.
- The competitor involved (if competing as an individual).

If the team captain is riding when scores are posted and will not be available within the allowed thirty-minute period, another team member may notify the rally office that an inquiry is likely.

Written Protest to the Discipline Ground Jury

If a team does not agree with the TD/steward's decision on a written inquiry, they may advance a written protest (utilizing the existing written inquiry form) to the discipline ground jury.

SECTION IV: Scoring

The decision must be made while the team is sequestered and within 10 minutes after the TD/steward's announcement of the decision to the team.

Written Protests must be:

Initiated by:

- The team captain, if competitor is on a team. The competitor involved may go with the team captain.
- The competitor involved (if competing as an individual).
- Made within 10 minutes of the TD/steward's announcement of the decision to the team.

Frivolous Protest

- During a rally, each team is allowed one "free" inquiry to the technical delegate. After the first, the TD may present to the ground jury any inquiry presented in which the decision of the judge was upheld and which the TD deems frivolous and not in the spirit of good sportsmanship. Any inquiry deemed frivolous, may be assessed 5 points by the ground jury.
- If any score change results, the chief scorekeeper must be notified by the official making the decision and changes recorded scores.

The ground jury will meet, review the written inquiry/protest form, make a decision, document the decision on the original written inquiry/protest form, and report its decision.

THE DECISION OF THE DISCIPLINE GROUND JURY IS FINAL AT REGIONAL RALLIES.

Written Appeal to the Overall Ground Jury/ Appeal Committee

(AT CHAMPIONSHIPS ONLY)

If a team does not agree with the discipline ground jury's decision on a written protest, they may advance an appeal (utilizing the existing written inquiry form) to the overall ground jury/appeal committee.

The team's decision to appeal must be made while the team is sequestered and within 10 minutes after the announcement of the discipline ground jury's decision to the team.

Appeals must be initiated by:

- The team captain, if competitor is on a team. The competitor involved may go with the team captain.
- The competitor involved (if competing as an individual).

THE DECISION OF THE OVERALL GROUND JURY/APPEAL COMMITTEE IS FINAL AT CHAMPIONSHIPS.

Article 55—Scoring of Excused

Excused competitors/mounts will receive same score as an elimination score for any phase from which they are excused. Competitors/mounts may rejoin the competition soon as they are able.

Article 56—Scoring of Elimination

1. An eliminated team receives one point for that games.
2. Specific reasons in Games:
 - Rider violates a specific rule of any game as set forth in the Games rules (e.g., failing to re-set a knocked over bending pole)
 - Failure to complete the game.
 - The last rider in every game must wear a white hatband or helmet cover. Infringement of this rule, or anyone else wearing the white hatband or helmet cover, will incur elimination.
 - If a head judge blows the whistle to move a game along, it should be considered an elimination.
 - Passing the wrong side of a post unless corrected.
 - Failure by the rider concerned to replace a post they have knocked down.
 - Any Games equipment being put in the rider's mouth at any time. The penalty for infringement is elimination.
 - Except when the rules allow riders to dismount, they must remain mounted (facing forward, legs astride the saddle). Should a competitor fall off and lose their mount, they must remount and resume the race from the point where they fell off. The penalty for infringement is elimination.
 - If a rider or mount breaks a piece of equipment so that it cannot be used to complete the game in the manner in which it was intended, the team will be disqualified from that game.

Article 57—Scoring of Disqualification

The discipline ground jury may disqualify a competitor and/or a team from competition, for the reasons stated in Article 21. Or the discipline ground jury may decide to issue a Yellow (Warning) Card in lieu of disqualifying a competitor. Decisions of the discipline ground jury are not appealable except at Championships.

1. If a Yellow Card is accessed to a competitor, it may or may not include penalty points. The discipline ground jury can access penalties ranging from 0 up to the maximum penalties as defined below. Any accessed penalties should be included in the "Other" column on the scoresheet and are deducted from the positive point score prior to combining them with the Horse Management Score.

Single Game Infraction—The maximum number of penalties accessible for infractions related to a single game is calculated by taking the number of teams in the game and adding 1, then dividing the total by 2.

Full Competition—The maximum number of penalties accessible for infractions related to the entire competition is calculated by taking the number of teams in the game

SECTION IV: Scoring

and adding 1, then dividing the total by 2. Next, multiply the number just calculated by the number of games played during the competition.

2. Competitors (or teams) who are disqualified from competition shall have all their scores from the competition stricken. If the disqualification of a competitor causes an already short team, to become a shortened team, then shortened team ghost scoring will apply.

Disqualified competitors and their horses may not take further part in the rally and may be asked to leave the grounds. A disqualified competitor/team may not receive an award.

Causes for disqualification in Games are:

- Late arrival for the start of the game
- Use of whips or spurs
- Using anything other than an open flat hand to strike the mount (including, but not limited to, Games equipment, the reins, stirrup leather)
- Intentionally striking or kicking another competitor's mount
- Kicking the mount from the ground, or with any part of the foot but the heel when mounted
- Improper dismounting (i.e., the rider intentionally bringing the leg over the withers instead of the croup)
- Rough or dangerous riding
- Interference by a rider or a mount with the progress of another team in the playing of a game. Interference is defined as having forward motion impeded or having to deviate from the chosen riding line
- Unauthorized assistance either during a game or in preparation for a game or anywhere on the competition grounds; cheering of a team or competitor must be done by pinny color, team, club/center or regional name only. General cheering only is allowed; specific instructions from non-team members are forbidden, including those from riders in other divisions
- A mount running loose away from its rider AND creating a hazard to the other mounts and competitors (a loose mount may be caught by any competitor or official already in the arena behind lines A and C; only the mount's rider, however, may enter the playing area to catch it)
- Use of rude, abusive, obscene or inappropriate language, gestures or behavior
- Un-sportsmanlike conduct
- Abuse of or cruelty to a mount
- Mount or rider leaving the arena before a game is completed
- A third false start
- Causing a significant delay in games play
- Not maintaining a constant rein contact with their mount while in the games arena.

- Dismounting in the games arena without permission
- Failure to remain mounted, remount, remain in place or walk out of the arena until excused or granted permission shall result in disqualification
- Occupying the incoming zone of the playing field
- Pulling or yanking on a mount's mouth is also prohibited as determined by the judge

Article 58—Team Scoring

1. Team scoring for Games is on a positive point basis. The total number of points earned in all the games will be added to the Horse Management score to determine the final team score. The final score is calculated using the below formula.

Riding scores are calculated using Article 52.

Horse Management bonus score = (number of games played) —(number of HM penalties).

Overall score = riding score + HM bonus score (possibly a negative number that reduces rather than increases the total score).

2. In extraordinary circumstances when a short team (four rider team) becomes a shortened team (three rider team) during the competition, the following team scoring will take effect.
 - A. In the event of the competitor being removed completely from the team. Ghost Horse Management scores will be determined per the Horse Management Handbook. The team will no longer be eligible for overall team awards but will still be eligible for Horse Management awards.
 - B. In the event of the competitor no longer being able to participate in the riding portion of the competition. They shall continue to earn Horse Management scores. The team will no longer be eligible for overall team awards but will still be eligible for Horse Management awards.

Article 59—Posting Scores

Depending on the length of the rally, scores may be posted multiple times during the rally or just once. Any time scores are posted there is a 30-minute inquiry period where competitors can inquiry regarding the scores (Article 54). After the final inquiry period, the only changes that can occur are if a transcription error has occurred. Following the final inquiry period, final scores for all competitors must be posted for review by competitors, parents, coaches, etc.

Anytime scores are posted during the competition, there will be an announcement of official score posting and time.

Article 60—Placing of Teams

The winning team is that with the best (highest) final score after riding scores and the Horse Management bonus score are added together.

SECTION V: Officiation

Overview

The use of appropriately licensed (US Equestrian, etc.) officials is always preferable. Regarding standard rallies, appropriately licensed officials may be required. However, realizing that not every area has Pony Club-oriented licensed officials easily available, rally organizers are asked to utilize suitably experienced personnel to fill official positions. Organizers needing help are encouraged to reach out to the appropriate discipline committee (refer to [www.ponyclub.org About/Contact Us/Activities Committees](http://www.ponyclub.org>About/Contact%20Us/Activities%20Committees) to find contact information for the USPC discipline committee members). These resource people, available by e-mail, or phone, can help with courses, officials, or other questions.

Article 61—Rally Organizer

The rally organizer serves as the manager of the competition. They must be on the grounds during competition and available to rally officials in the event a problem arises concerning the facility or equipment. Rally organizers do not participate in the officiation, unless required due to extenuating circumstances. They must engage individuals necessary to fill all official capacities at the competition. Full details and job descriptions for rally organizers are available in the Rally Organizer's Guide.

Article 62—Technical Delegate (TD)

The technical delegate is the person to whom an inquiry is presented by the team captain in the event of a question regarding mathematical errors or scoring irregularities. If the initial inquiry to the technical delegate fails to resolve the question at hand, the discipline ground jury then makes a final decision. The technical delegate may not be a member of the discipline ground jury.

Per the appropriate discipline rulebook the organizer shall appoint a knowledgeable person to serve as technical delegate. The technical delegate shall act with complete impartiality and report to the organizer and appropriate discipline committee, protecting the interests of competitors, judges, officials and the competition organizers. The technical delegate shall have no connection with the management or judging of a competition. No Pony Club rally competition shall be organized and held without the presence of a technical delegate.

The technical delegate is responsible for:

- A. Ensuring the competition is organized and managed in strict compliance with the appropriate discipline rules
- B. Inspecting competition facility prior to the competition with appropriate officials
- C. Supervising the horse inspections
- D. Once the competition begins, the technical delegate is responsible for accounting for the presence of all competitors and horses on rally grounds. Any withdrawals

of horses or riders must be reported to the technical delegate as soon as possible.

- E. Supervising the technical conduct of the competition.
- F. Reporting any infraction or violation of the competition rules and regulations to the organizer or appropriate people, by any competitor, coach, manager, competition official, staff member or any other person present on the competition grounds, and seeing that immediate action is taken
- G. Protecting the interests of competitors, judges, officials and the competition organizers
- H. Furnishing the discipline committee with a complete written report on the competition, including any infractions or violations of the rules, within three days following completion of the competition. (See Appendix V).

The technical delegate is authorized to insist on alterations to the facility and competition areas if, in their opinion, they do not comply with the established limits for the competition.

Article 63—Discipline Ground Jury

The discipline ground jury is the group that adjudicates the rally. The discipline ground jury makes proper inquiries into both sides of cases in all protests concerning decisions made by the technical delegate and other officials during a rally.

The discipline ground jury shall be composed of the chief judge, the chief horse management judge, and one other Pony Club games knowledgeable person as appointed by the rally organizer.

The following persons are ineligible to serve on the discipline ground jury:

1. Any competitor, manager, chaperone, coach or owner of a horse entered in the competition
2. Any close relative of a person named in item 1. above
3. Any instructor or trainer of any competitor or horse entered in the competition
4. The organizer or any member of the organizing committee
5. No other horse management judge from that competition
6. The technical delegate
7. Any member of the overall ground jury/appeal committee

Duties of the discipline ground jury:

- A. The discipline ground jury is ultimately responsible for the judging of the rally and for settling all problems that may arise during its jurisdiction. Together with the technical delegate and organizing committee shall ensure that all arrangements for the rally, including that all competition areas are appropriate. If, after consultation with the technical delegate, the discipline ground jury is not satisfied with the arrangements or areas, it has the authority to modify them.

SECTION V: Officiation

- B. The discipline ground jury will be responsible for determining objections against decisions by technical personnel, including judges and time-keepers, and may substitute their judgement for that of any judge or official, whether or not in favor of the competitor.
- C. The members of the discipline ground jury are obliged to be on the grounds from the official rally opening until awards have been made.
- D. Any member of the discipline ground jury has the duty and authority at any time during the rally to disqualify any competitor who is unfit to continue because of physical exhaustion or impairment, abusive or dangerous behavior. There is no appeal against such a decision.

Article 64—President of the Discipline Ground Jury

The chief overall judge shall be president of the ground jury.

Article 65—Overall Ground Jury/Appeals Committee (for Multiple Championships)

At Championships (when multiple disciplines are competing at the same time and on the same facility), there will be an overall ground jury/appeals committee composed of three to five persons to include: the VPA (if not the organizer), the Championships horse management organizer, and one or more knowledgeable horse persons designated by the organizer, one of whom will be designated president.

The purpose and duties of the overall ground jury/appeals committee include:

- Determine dress requirements for turnout inspections and competition; and responsibility for waiving of dress requirements when the heat/humidity index so indicates
- Decide issues that affect all disciplines at the Championships, so as to promote uniformity among the competitions
- Handle instances regarding the uniform application of disciplinary action for poor sportsmanship, cruelty or misbehavior by a competitor
- Make a proper inquiry into both sides of the cases in all appeals concerning decisions made by the discipline ground jury, or referred to the appeal committee by the discipline ground jury

The decision of the overall ground jury/appeals committee is final.

The following may not serve on the overall ground jury/appeals committee at a Championships:

- Anyone serving as a technical delegate
- Anyone serving on a discipline ground jury
- Anyone serving as a CHMJ for the competition
- Anyone serving as a judge for the competition

Article 66—Horse Management Judges

1. All competitions shall include judging of Horse Management. Horse Management shall be judged in accordance with current USPC Horse Management Handbook. At all events, horse management judges will judge safety standards throughout the day.
2. The horse management judges shall be responsible for conducting stable, turnout and turnback inspections.
3. Horse management judges shall be responsible for safety checks. The safety checks will be performed in assigned areas, as close to warm up and jumping areas as feasible.

Article 67—Chief Horse Management Judge (CHMJ)

One member of the rally horse management staff will be designated as the chief horse management judge. If the rally is a standard rally for Championships, the chief horse management judge must be selected from the CHMJ list on the USPC website.

Article 68—Line Judges

There must be a line judge and an assistant for lines A and C. (The overall judges are positioned at line B.) The chief line judge at line A is the starter. The starter's duties are defined in Article 43 in the general games rules. The assistant is stationed on the opposite side of line A from the starter. Together, they make a preliminary ruling on the order of finish. They also judge line A and the 6-yard area for any infractions of the rules. The line C judge and assistant are stationed at each end of line C and judge that line and the 6-yard area for rules infractions. The line C judge also acts as liaison with the lane judges for the overall judges.

Article 69—Lane Judges

There shall be at least one lane judge for each lane of competition. They are to watch their assigned lane for rules infractions (e.g., an improper bend) during the playing of a game. They are stationed behind the collecting area behind line C, and should be in a position to clearly see the lane they are judging. They should report any problems to the line C judge.

Article 70—The Judging Committee

This committee is composed of the overall judges, the starter (the chief line judge) and the line C judge. The judging committee determines the final placing in each race, as well as eliminations and disqualifications in a game. They must consult with the assistant line judges at lines A and C and with the lane judges as necessary. If the judging committee cannot agree on a call, the chief overall judge shall bear the responsibility of making the final call.

SECTION V: Officiation

Article 71—Chief Overall Judge

They are responsible for the overall conduct of the competition, and make the final decisions as to placing, rule infractions, eliminations and disqualifications. There shall be one overall judge for each two lanes of competition, and one overall judge is designated as the chief overall judge. The organizer shall appoint the chief judge. The chief overall judge shall also serve as president of the ground jury.

Article 72—Official's Equipment

The starter must be equipped with a flag and whistle. The chief overall judge must also have a whistle. No other official shall carry a whistle. All officials must have pad and pencils.

Article 73—Inspection Panel

An inspection panel made up of the president of the discipline ground jury, the CHMJ, and a veterinarian or other qualified horse person, will officiate over the horse inspections (jogging). The veterinarian's decision shall be final when a judge or the steward requests an inspection or examination as to the serviceable soundness of a horse. In the absence of a veterinarian, the judges or the steward shall have the right to excuse a horse from further participation on the grounds of unsoundness.

Article 74—Veterinarian

1. The veterinarian should be a part of the inspection panel for all **horse inspections**.
2. Regional competitions should have a qualified veterinarian present or on call for all jumping phases of the competition.
3. The veterinarian shall assist the organizer in all matters pertaining to the health and welfare of the horses at the competition.
4. The veterinarian, when required to be present at a competition, shall have the right to inspect and examine any horse at the competition. The judges or the steward may request an inspection or an examination of any horse.
5. The veterinarian's decision shall be final when a judge or the steward request an inspection or examination as to the serviceable soundness of a horse. In the absence of a veterinarian, the judges or the steward shall have the right to excuse a horse from further participation on the grounds of unsoundness.
6. In any suspected case of use of drugs, the veterinarian shall be permitted to take blood, urine and/or saliva sample(s) to test for drug residues.

Article 75—Chief Scorerkeeper

1. The chief scorekeeper is responsible for prompt and accurate scorekeeping. The judges and timekeepers provide factual data for the chief scorekeeper to use in the calculation of scores and place standings.
2. Accurate, up-to-the-minute scorekeeping is very important to keep the competitors, officials and spectators informed. Therefore, the judges and the chief scorekeeper shall work in close cooperation with the announcer.
3. The chief scorekeeper shall appoint such assistants as they may require for the work. All scoring shall be conducted with complete impartiality.

Article 76—Required Medical Personnel

1. For Mounted Rallies—An EMT-Basic (paid or volunteer) is required onsite one hour prior to the first ride of the rally and stay until riding concludes for the day. The EMT or rally organizer must be aware of the closest ambulance and hospital locations.
2. The EMT must:
 - Have CPR certification and license to perform basic assessment and non-invasive treatment.
 - Not have any other duties at the mounted rally.
 - Have a reliable means of communicating with the local EMS service and knowledge of the nearest hospital.
 - Have direct communication with all riding areas, especially those out of view.
 - Coordinate with the rally organizer on how to handle injured parties.
3. Additional Information:
 - A. An EMT who is Intermediate or Paramedic level, both meets and exceeds the minimum requirement.
 - B. Facility requirements may exceed the minimum USPC EMT requirement.
 - C. Rallies run as recognized events may exceed the minimum USPC EMT requirement.
 - D. An on-site ambulance is highly recommended, but not required.

SECTION VI: Appendices

Appendix I: Mounted Competitions Scoring Inquiry/Protest/Appeal Form page 1

Remember:

- Only Competitors have the right to dispute scores and can participate in the process.
- Before this form can be used, a verbal inquiry must have been made to the CHMJ for horse management score questions.
- After submission to the TD/Steward, no additional information can be added by the team.

Date: _____ Discipline: _____ Division: _____ Team #s _____

Team Captain Name & Phone Number: _____

Team Member # for Protest: _____ Team Member Certification: _____

State infraction and provide points assessed:

Statement of Protest:

References (Name reference and page number):

Signature of Team Captain/Competitor: _____

SECTION VI: Appendices

Appendix I: Mounted Competitions Scoring Inquiry/Protest/Appeal Form page 2 Written Inquiry/Protest/Appeal Review For Official Use Only

Written Inquiry Disposition: Date/time: _____

Approved: _____ Denied: _____ Points awarded if any: _____

Technical Delegate: _____

CHMJ (if HM related) _____

Team Captain _____

Requesting Advance to Protest Yes: _____ No: _____

Protest Disposition: Date/time: _____

Approved: _____ Denied: _____ Points awarded if any: _____ Penalty, if any: _____

Discipline Ground Jury: _____

Team Captain: _____

Requesting Advance to Appeal (Championships ONLY) Yes: _____ No: _____

Appeal Disposition: Date/time: _____

Approved: _____ Denied: _____ Points awarded if any: _____ Penalty, if any: _____

Overall Ground Jury/Appeal Committee (Championships ONLY): _____

Team Captain: _____

Received by Scorer: (to indicate receipt and adjustment of a change)

SECTION VI: Appendices

Appendix II Heat Illness and Heat Index Chart

HEAT ILLNESS	Symptoms	What to Do
Heat Stroke	<ul style="list-style-type: none"> • Confusion • Fainting • Seizures • Excessive sweating or red, hot, dry skin • Very high body temperature 	<ul style="list-style-type: none"> • Contact Medical Personnel, EMT, or Call 911 <p><i>While waiting for help:</i></p> <ul style="list-style-type: none"> • Place person in shady, cool area • Loosen clothing, or remove outer clothing • Fan air, place ice packs in armpits, apply cool compresses • Provide fluids (water)
Heat Exhaustion	<ul style="list-style-type: none"> • Cool, moist skin • Heavy sweating • Headache • Nausea or vomiting • Dizziness • Light headedness • Weakness • Thirst • Irritability • Fast Heart Beat 	<ul style="list-style-type: none"> • Place person in shady, cool area • Provide fluids (water) • Cool person with cold compresses, ice packs, fan
Heat Cramps	<ul style="list-style-type: none"> • Muscle Spasms 	<ul style="list-style-type: none"> • Rest in cool, shaded area • Drink water • Wait a few hours before returning to play

Heat Index (Apparent Temperature) Chart

	RELATIVE HUMIDITY										
	0%	10%	20%	30%	40%	50%	60%	70%	80%	90%	100%
70°	64	65	66	67	68	69	70	70	71	71	72
75°	69	70	72	73	74	75	76	77	78	79	80
80°	73	75	77	78	79	81	82	85	86	88	91
85°	78	80	82	84	86	88	90	93	97	102	108
90°	83	85	87	90	93	96	100	106	113	122	+
95°	87	90	93	96	101	107	114	124	136	+	+
100°	91	95	99	104	110	120	132	144	+	+	+
105°	95	100	105	113	123	135	149	+	+	+	+
110°	99	105	112	123	137	150	+	+	Danger Zone		
115°	103	111	120	135	151	+	+				
120°	107	116	130	148	+	+	+				
125°	111	123	141	+	+	+	+				
130°	117	131	+	+	+	+	+				

This chart is based upon shady, light wind conditions.
Exposure to direct sunlight can increase the HI by up to 15°F.
“+” indicates the heat index temperature is so great it is off the scale.

SECTION VI: Appendices

Appendix III: Chaperone and Emergency Contact Information

Team Chaperones vs. Emergency Contacts

When competitors under the age of majority (minors) participate in a rally, there will be a designated “Official Team Chaperone.” In the situation of scramble teams, the official team chaperone will be appointed by the rally officials and will be so noted in the rally program. The team chaperone serves as the team contact for rally and a responsible guiding presence to prepare the team for success. Competitors who are above the age of majority (adults) participating in a rally will not have a designated chaperone but must submit the name and contact information for their emergency contact.

Team Chaperones

Time Commitment

The official team chaperone is responsible for team members during the hours of competition and on competition grounds only (from arrival on grounds until departing rally ground at beginning and end of each day of competition).

Transportation, Driving and Lodging

Decisions to allow a competitor to drive or not, who they can or cannot ride with, who they can or cannot have in a vehicle that they are driving, where they stay at night and with whom they stay, and who is to be responsible for a competitor are all decisions that must be made by the parent/legal guardian. These decisions are not a decision of USPC, their region, club/center, or the rally organizer. Specific arrangements must be made by and between the parent/legal guardian and the adult assuming any of these responsibilities in the absence of the parent/guardian.

Preparing Your Team for Success

- Initiate contact with all team members prior to leaving for the competition and gather cell phone numbers as appropriate. In cases of scramble team members, request contact information from the rally secretary. Share this information with team captain and/or stable manager.
- Encourage the team to have meetings prior to leaving for rally. Be sure all members of a scramble team are included in the decision-making process, either by email or phone contact, if a distance away.
- Discuss team equipment, review all rules that apply and any decisions regarding snacks, drinks, plans for meals, etc. Determine how the team members plan to provide snacks and drinks (i.e., each team member contribute a sum of money to a pot or each member is assigned specific items to bring). If each is contributing money, it must be collected before the rally. Be sure to know who is bringing cooler(s), as to avoid a trip to the local store.

- Plan arrival time at the competition site and any details such as arrangements for ordering bedding, if needed, and who is assigned to do this (again collect money in advance if needed).
- On the first day of the rally, gather the team together before they separate for the night and make plans for the next day. Include a review of their competition schedule and how they can best work together to help each other prepare.
- Determine a regular meeting place and de-brief the team at the end of each day of competition. Take this opportunity to offer words of praise, acknowledge their accomplishments, and encourage the sense of teamwork and team building. Guide the team towards constructive criticism and steer them away from finger pointing. Have the team make plans for the next day concerning time they will arrive on the competition grounds, who will feed horses the next morning, who will re-supply the tack room cooler with ice, drinks and snacks (get requests for drinks/ snacks) and make the plans for lunch. Be sure any plans for cooler and/or lunch delivery follow any requirements as stated in the competition entry and they understand the plan. Have the team leave with a plan for the next day in place before they go off for an evening of relaxation.

Emergency Contacts

Anyone listed as an emergency contact for a competitor should be reachable by phone for the duration of the competition. Emergency contacts do not need to be on the competition grounds, but ideally are also within driving distance of the competition in the case of an emergency.

SECTION VI: Appendices

Appendix III Chaperone Form

To be completed by the chaperone and turned in with the rally entry for USPC members below the age of majority.

Chaperone duties shall include:

1. The primary function of the "Official Team Chaperone" is to ensure that there is a contact person for every USPC member below the age of majority, on the grounds for the duration of the competition.
2. While multiple Chaperone Forms may be turned in for a single team, only one person will be designated the Official Team Chaperone. If the Official Team Chaperone must leave the grounds during the competition, they must delegate the team chaperone duties to another responsible adult, making it clear that they are to respond to rally officials and any team members in your absence.
3. Be present and available to rally officials and all team members for the duration of the competition.
4. Being in contact with parents/guardians for all team members during competition hours.
5. Being in contact with all team members and their parents/guardians outside of competition hours.
6. Have copy of and be familiar with the current discipline rulebook and the current Horse Management Handbook and Rules for rallies. Rulebooks available for download from www.ponyclub.org.
7. Be aware that USPC members are required to wear a current, up to date USPC medical card/bracelet on their arm at all USPC activities.
8. Be familiar with the effects of heat and humidity and the potential risk for heat related illness. Take an active role in helping to keep all team members well hydrated and take every opportunity to encourage water breaks.
9. Uphold USPC Substances and Weapons Policy which prohibits the inappropriate or illegal use of any substance, including but not limited to drugs or alcohol, by anyone participating in any manner. Weapons of any kind are forbidden. Refer to About/About the Organization/By-Laws, Policies and Resolutions on www.ponyclub.org for the full policy statement.
10. Remember that administration of medications is the sole responsibility of the parent/guardian.

I have read and understand the duties of a chaperone as listed above.

Chaperone for the following team or individual(s)

Name of Chaperone

Cell Phone Number

Signature

Date

SECTION VI: Appendices

Appendix III Emergency Contact Form

for USPC Members Above the Age of Majority

The age of majority is the threshold of adulthood in law. As USPC members above the age of majority are adults in the eyes of the law and therefore responsible for themselves; USPC does not require a “chaperone” for these members at competitions. USPC does require that members above the age of majority submit Emergency Contact information for each competition. Age of majority varies per state.

USPC Member: _____ Current Age: _____ State of Residence: _____

Competition Name: _____ Competition Date: _____

Emergency Contact Name: _____

Emergency Contact Relationship to Competitor: _____

Emergency Contact Home Phone Number: _____

Emergency Contact Cell Phone Number: _____

An additional Emergency Contact can be included, but is not required.

Secondary Emergency Contact Name: _____

Secondary Emergency Contact Relationship to Competitor: _____

Secondary Emergency Contact Home Phone Number: _____

Secondary Emergency Contact Cell Phone Number: _____

SECTION VI: Appendices

Appendix V USPC Games Rally Technical Delegate's Evaluation and Report

(This form is also available electronically on the USPC website.)

*=information required; circle yes or no when you see **(yes/no)**.

TD/Steward's Name * _____ Phone * _____

TD/Steward's Email Address * _____

TD/Steward's License number and affiliation _____

Organizer's Name * _____ Phone * _____

Organizer's Email Address * _____

CHMJ Name* _____ Phone * _____

CHMJ Email Address * _____ Number of AHMJ's* _____

Rally Information

Region * _____ Rally Start Date * _____ Rally End Date * _____

Rally locations (please include all if multiple) _____

Is this a standard rally? * _____

Did you have a CURRENT copy of the Discipline's Rulebook? * **(yes/no)**

Did you read the rulebook prior to attending the rally? * **(yes/no)**

Was the entire rally conducted according to these rules? * **(yes/no)**

Did Horse Management function according to the rules? * **(yes/no)**

Did you have any problem with a stated rule? * **(yes/no)** If yes, please tell us why. _____

Did you have a situation for which there was not a stated rule? * **(yes/no)** If yes, please describe the situation. _____

Did any competitors receive Yellow Cards given during the rally? **(yes/no)** If yes, how many and why. _____

Were any competitors disqualified during the rally? * **(yes/no)** If so, please tell us who and why. _____

SECTION VI: Appendices

Was the rally well-organized? **(yes/no)** Please describe. _____

Were the facilities suitable for all phases of the rally? **(yes/no)** If no, please describe areas of concern. _____

Were the organizers and other officials friendly and supportive to competitors and each other? * **(yes/no)**

Was sufficient personnel provided to manage all phases? * **(yes/no)**

Were medical personnel & equipment (EMT, ambulance) on the grounds during mounted activities and on call at all times? * **(yes/no)**

Were any accident reports filed? * **(yes/no)**

For the duration of the rally, was safety placed as a priority? **(yes/no)** Please describe. _____

Were the communications suitable for all phases of the rally? (yes/no) If no, please describe areas of concern. _____

Were briefings held? (yes/no) Please describe. _____

Was the rally a learning experience for all competitors? * **(yes/no)** Please describe. _____

Do you feel you were given all the materials to do your job effectively? * **(yes/no)** If no, please describe why not. _____

Horse Management Review

As the Technical Delegate/Steward, you are charged with the first level of reviewing the decisions in Horse Management. Under the rules of competition, the initial protest from the decision of the Chief Horse Management Judge is to the Technical Delegate/Steward. A protest can only be made by the team or individual competitor against whom an adverse decision is made. Therefore if a protest comes to you to reconsider the decision of the Chief Horse Management Judge and you do NOT sustain the decision of the judge, the protest is concluded. If you do sustain the Chief Horse Management Judge, then a protest can be placed before the Discipline Ground Jury.

Were all inquiries/protests that were brought to you as TD/Steward in written form on the official form? * **(yes/no)**

Do you have any comments on the Horse Management competition at this rally? _____

SECTION VI: Appendices

Do you have any additional comments or thought you would like to share? _____

Rally Competitor Numbers

Please utilize the lines below to indicate what competition divisions were offered and the number of teams and competitors in each.

	Level/ Division*	Number of Teams*	Number of Competitors*	Number of Competitors with D-2 Certification above 10 years of age*	Number of Competitors with C-1 Certification above 12 years of age*
Youth Walk/Trot	_____	_____	_____	_____	_____
Junior Walk/Trot	_____	_____	_____	_____	_____
Senior Walk/Trot	_____	_____	_____	_____	_____
Youth Intermediate	_____	_____	_____	_____	_____
Junior Intermediate	_____	_____	_____	_____	_____
Senior Intermediate	_____	_____	_____	_____	_____
Youth Open	_____	_____	_____	_____	_____
Junior Open	_____	_____	_____	_____	_____
Senior Open	_____	_____	_____	_____	_____
Other (please specify)	_____	_____	_____	_____	_____

President of the Ground Jury's Name * _____ Phone * _____

President of the Ground Jury's Email Address * _____

President of the Ground Jury's Experience (Please describe) _____

SECTION VI: Appendices

Appendix VI Games Coaching Guidelines Form

Each coach should have a copy and a signed copy submitted with entries. Photocopy as necessary.

Penalties for violating these coaching guidelines will be assessed by the discipline ground jury and/or overall ground jury under the rules governing unauthorized assistance. Any coach not adhering to the rules set forth below may be removed from their position for the duration of the phase and/or competition.

Coaches are recommended for Games rallies and Championships. There may be one or more coaches per team; the organizer or ring steward may limit the number of coaches in a warm-up area at any given time.

Agreement

By signing this form, you:

- Agree to be familiar with and observe all USPC By-Laws, Policies and competition rules.
- Agree to be governed by Horse Management guidelines as expected of competitors, including appropriate attire, footwear and conduct.
- Agree to adhere to the USPC Conflict of Interest and Code of Ethics Policies in all your actions and decisions.
- Agree to conduct yourself in a fair and courteous manner.

Coaches Must

- Check in as requested and attend any official coaches' briefings.
- Be familiar with, understand and comply with the current USPC discipline and Horse Management rules.
- Be aware of the welfare of horse and rider.
- Wear identification as provided by the organizer/secretary during the competition times.
- Follow all discipline coach parameters outlined in the discipline rulebook.
- Assist competitors in learning and understanding all rules pertinent to the competition.
- Help any Pony Club competitor who asks for help or who is present without a coach.

Coaches Must Not

- Enter the barn except during authorized visiting times.
- Interfere with the immediate care of the mount under penalty of elimination of the competitor.
- Coach in a manner that interferes with the warm-up of other competitors.
- Be the organizer, and member of the organizing committee or any other official of the competition.
- Be a team chaperone.
- Be a regional supervisor at a regional competition.

Coaching Duties

- Warming-up competitors for competition in the designated warm-up areas only.
- In addition, a coach may lead a competitor's mount into the arena area.
- Coaches may observe but not participate in (unless requested), soundness checks or horse inspections.
- Meet with the team to discuss ride times, planning and how to best utilize the coach within the team.

Communications between Coaches and Competitors

- Coaches may communicate with the competitors during the official briefing and any subsequent briefings as required by the organizer and in the warm-up area prior to and following the competitor's ride.
- Coaches may accompany competitors during their ride, arena inspection, course walks or any other subsequent times competition areas are open for warm-up, during which they may give advice and coach.

Competitors who wish to Coach while Competing

Championships competitors who are 18 years of age as of January 1 of the competition year may coach other members recognizing that:

- No scheduling changes will be made to accommodate coaching /riding times.
- Care of mount and other competitor responsibilities take precedence over coaching.

All phase coaches must sign that they have read this sheet:

I _____ have read and agree to follow the USPC Games Rulebook and above guidelines for coaching.

Printed Name: _____ Signature: _____

Date: _____ Cell Phone: _____ Email: _____

Please list the competitors/teams you are coaching:

1. _____
2. _____
3. _____
4. _____
5. _____
6. _____

SECTION VI: Appendices

Appendix VII Games Yellow (Warning) Card

UNITED STATES PONY CLUBS

A yellow warning card may be issued by the discipline ground jury after being notified by a technical delegate, steward, or competition official at a USPC competition to any competitor, spectator or participant for improper conduct, or for noncompliance with the rules. When issuing a yellow card, the discipline ground jury may assess penalty points as outlined in Article 21 and 57.

Important information to know about the issuance of a Warning (Yellow) Card:

1. A Yellow Card is a warning with possible attached penalty points given for any infraction that is a disqualifiable offense.
2. A Yellow Card may be, but is not required to be given before the disqualification of a competitor or team.
3. A Yellow Card that incurs penalty points that will be recorded in the "Other" column of the scoresheet.
4. There is no appeal against receiving a Yellow Card.
5. A copy of any Yellow Card issued must be sent to the Activities Department, activities@ponyclub.org.

Issued to: (Name) _____ Competitor # _____

Region/Club/Center _____

Address _____

City/State/Zip _____

At the following competition: _____

Date/Time of incident: _____ Description of incident: _____

(please use back of page if necessary)

Issuing Official: (print) _____ Position: _____

Signature: _____ Date: _____

Phone: _____ Email: _____

Activities Department • United States Pony Clubs • 4041 Iron Works Parkway • Lexington, KY 40511 •
859.254.7669 • Fax 859.223.4652 • www.ponyclub.org

SECTION VI: Appendices

Appendix VIII Approved and Unapproved Bits



APPROVED – Smooth mouth snaffle bit with no more than two joints



APPROVED – Smooth mouth snaffle bit with one joint



APPROVED – Mullen mouth snaffle bit



APPROVED – Full cheek smooth mouth snaffle bit



NOT APPROVED – Slow twist snaffle bit



APPROVED – Smooth mouth Uxeter kimberwick or plain kimberwick with low or medium port; reins to be attached to bit ring only, not to snaffle or curb hole in the bit ring



APPROVED – Smooth Pelham

SECTION VI: Appendices



NOT APPROVED – Jointed Uxeter kimberwick or jointed plain kimberwick



NOT APPROVED – Jointed Pelham



NOT APPROVED – Pelham with port



APPROVED – Jumping hackamore



APPROVED – Hackamore with shanks less than 6" long



NOT APPROVED – Shanks longer than 6"

SECTION VI: Appendices

Appendix IX Algorithm for Formation of Games Teams

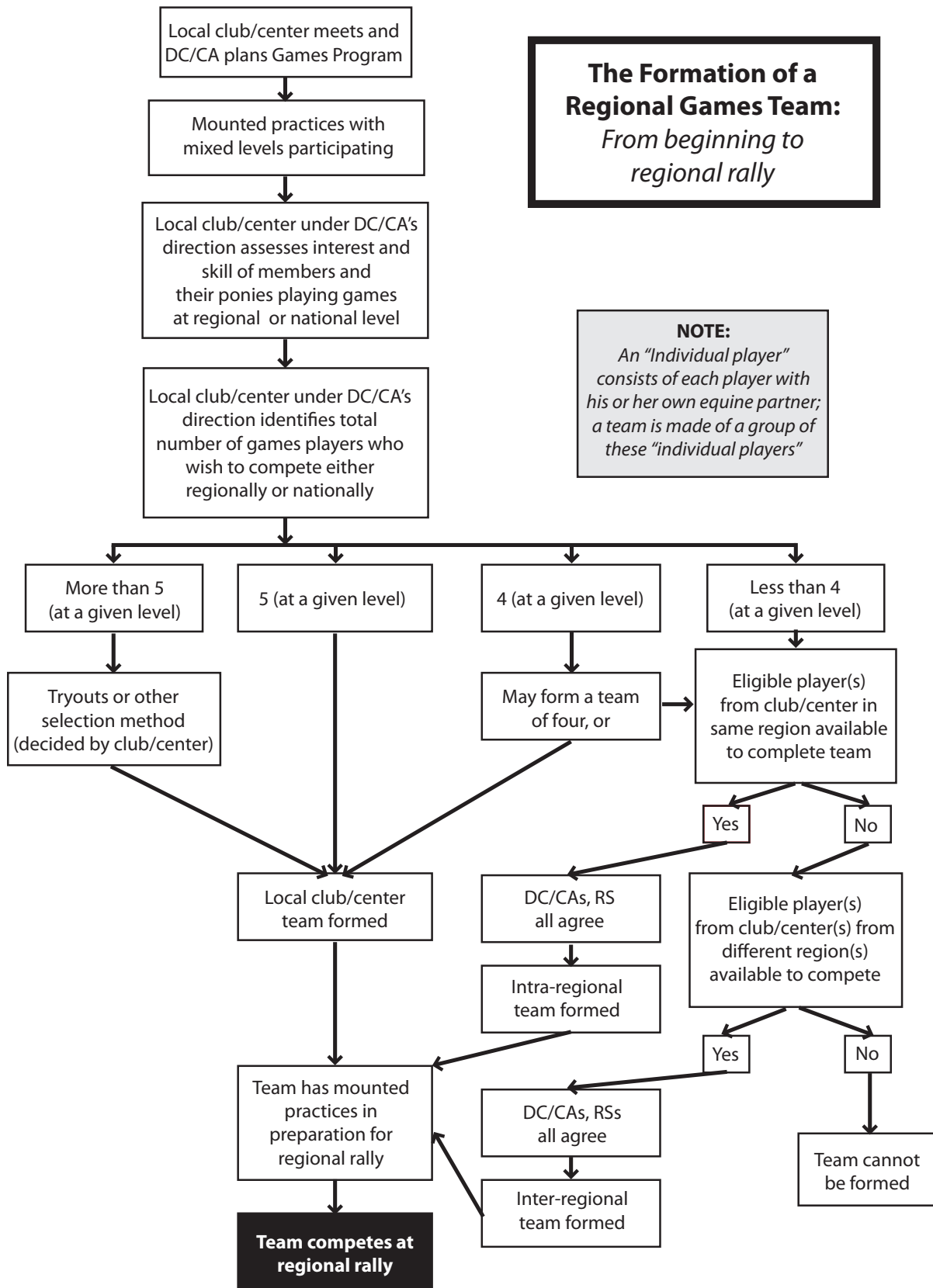

SECTION VI: Appendices

Appendix IX Algorithm for Formation of Games Teams

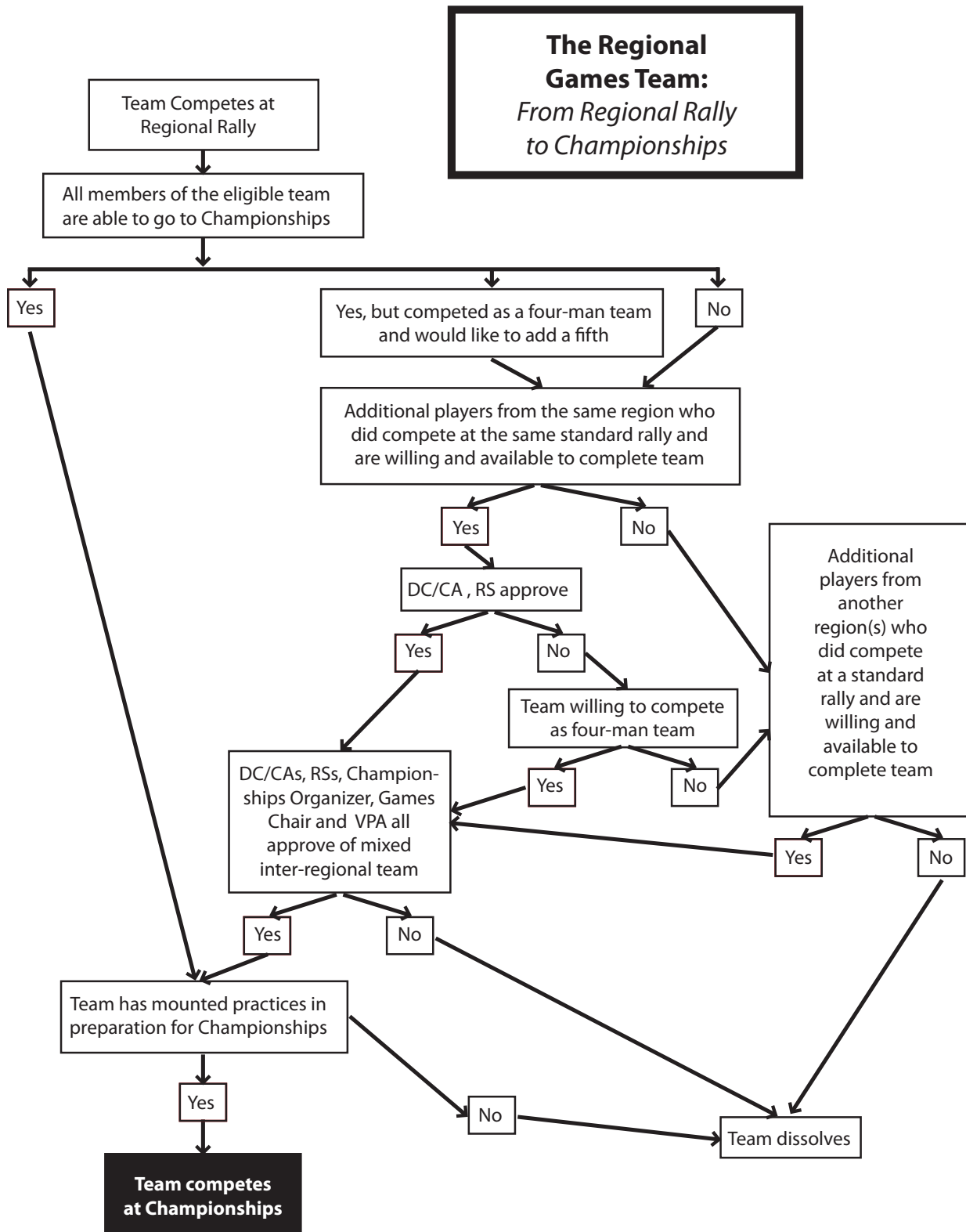

SECTION VI: Appendices

Appendix X Mount/Rider Weight Requirements

Rider Weight Limit:

The rider weight will be no more than 18% of the mount's approximate weight.

Instructions for Measuring Heart Girth (H) and Length (L) *(measure with mount standing square)*

1. Using a measuring tape, measure your horse's heart girth in inches. Wrap the tape measure around the from the base of the withers down to a couple of inches behind the horse's front legs, under the belly, then up the opposite side to where you started. If you are unsure how to measure the heart girth, please refer to the dotted line on the diagram. Record the number (H).
2. Using the measuring tape, measure your horse's length (from the mount's point of shoulder to the point of buttock) in inches. If you are unsure how to measure the length, please refer to the solid line on the diagram. Record the number (L).
3. Once you have the two numbers recorded, use the formulas provided below to calculate the maximum rider weight.

Formulas:

Approximate Mount Weight (W) = (Heart girth Measurement in inches squared X Length)/330

$$W = (H^2 \times L) / 330$$

Maximum Rider Weight (M) (dressed and ready to ride) = Approximate Mount Weight X 18%

$$M = W \times .18$$

Example:

If Mount Heart Girth = 58 inches

Mount Length = 63 inches

Then Maximum Rider Weight = 116 Pounds.

$$(58^2 \times 63) / 330 = 642 \text{ lbs. Approximate Mount Weight}$$

$$642 \times .18 = 116 \text{ lbs. Maximum Rider Weight}$$

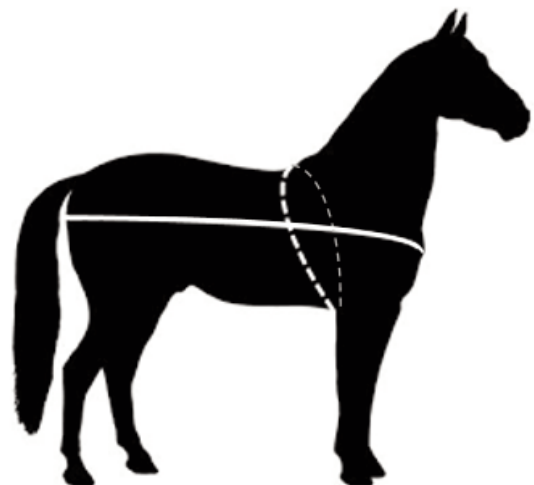

Pre-calculated maximum rider weights are located in the chart located on the next page. Find the heart girth measurement on the top row, and the length measurement along the left side. The maximum weight of the rider will be where those numbers converge.

SECTION VI: Appendices

		Horse's Heartgirth (in)																															
		40	41	42	43	44	45	46	47	48	49	50	51	52	53	54	55	56	57	58	59	60	61	62	63	64	65	66	67	68	69	70	71
45	41	43	45	48	50	52	54	57	59	61	64	66	69	72	74	77	80	83	85	88	91	94	97	101	104	107	110	113	117	120	124	127	131
46	42	44	46	49	51	53	55	58	60	63	65	68	70	73	76	79	82	84	87	90	93	96	100	103	106	109	113	116	119	123	126	130	134
47	43	45	47	50	52	54	57	59	62	64	67	69	72	75	78	80	83	86	89	92	95	99	102	105	108	112	115	119	122	126	129	133	137
48	44	46	48	51	53	55	58	60	63	65	68	71	74	76	79	82	85	88	91	94	97	101	104	107	111	114	118	121	125	128	132	136	140
49	45	47	49	52	54	57	59	62	64	67	70	72	75	78	81	84	87	90	93	96	99	103	106	109	113	116	120	124	127	131	135	139	142
50	46	48	50	53	55	58	60	63	65	68	71	74	77	80	83	86	89	92	95	98	101	105	108	112	115	119	122	126	130	134	137	141	145
51	47	49	51	54	56	59	61	64	67	70	72	75	78	81	84	87	90	94	97	100	104	107	110	114	118	121	125	129	132	136	140	144	148
52	48	50	52	55	57	60	63	65	68	71	74	77	80	83	86	89	92	95	99	102	106	109	113	116	120	124	127	131	135	139	143	147	151
53	49	51	53	56	59	61	64	67	69	72	75	78	81	84	87	91	94	97	101	104	108	111	115	118	122	126	130	134	138	142	146	150	154
54	50	52	54	57	60	62	65	68	71	74	77	80	83	86	89	92	96	99	103	106	110	113	117	121	124	128	132	136	140	144	148	153	157
55	50	53	55	58	61	63	66	69	72	75	78	81	84	87	91	94	97	101	104	108	112	115	119	123	127	131	135	139	143	147	151	156	160
56	51	54	56	59	62	65	67	70	73	76	79	83	86	89	92	96	99	103	106	110	114	117	121	125	129	133	137	141	145	150	154	158	163
57	52	55	57	60	63	66	69	72	75	78	81	84	87	91	94	98	101	105	108	112	116	120	124	128	132	136	141	145	149	154	158	163	168
58	53	56	58	61	64	67	70	73	76	79	82	86	89	92	96	99	103	106	110	114	118	122	126	130	134	138	142	146	151	155	159	164	169
59	54	57	60	62	65	68	71	74	77	80	84	87	90	94	97	101	105	108	112	116	120	124	128	132	136	140	144	149	153	158	162	167	171
60	55	58	61	63	66	69	72	75	79	82	85	88	92	95	99	103	106	110	114	118	122	126	130	134	138	143	147	151	156	160	165	170	174
61	56	59	62	64	67	70	73	77	80	83	87	90	93	97	101	104	108	112	116	120	124	128	132	136	141	145	149	154	158	163	168	172	177
62	57	60	63	65	68	72	75	78	81	85	88	91	95	99	102	106	110	114	118	122	126	130	134	139	143	147	152	156	161	166	170	175	180
63	58	61	64	67	70	73	76	79	83	86	89	93	97	100	104	108	112	116	120	124	128	132	136	141	145	150	154	159	164	168	173	178	183
64	59	62	65	68	71	74	77	80	84	87	91	94	98	102	106	109	113	117	122	126	130	134	139	143	147	152	157	161	166	171	176	181	186
65	60	63	66	69	72	75	78	82	85	89	92	96	100	103	107	111	115	119	123	128	132	136	141	145	150	154	159	164	169	174	179	184	189
66	61	64	67	70	73	76	80	83	86	90	94	97	101	105	109	113	117	121	125	130	134	138	143	147	152	157	162	166	171	176	181	187	192
67	61	64	68	71	74	77	81	84	88	91	95	99	103	107	111	115	119	123	127	132	136	140	145	150	154	159	164	169	174	179	184	189	195
68	62	65	69	72	75	78	82	85	89	93	96	100	104	108	112	116	121	125	129	134	138	143	147	152	157	162	167	172	177	182	187	192	198
69	63	66	70	73	76	80	83	87	90	94	98	102	106	110	114	118	122	127	131	135	140	145	149	154	159	164	169	174	179	184	190	195	201
70	64	67	71	74	77	81	84	88	92	95	99	103	107	111	116	120	124	128	133	137	142	147	152	156	161	166	171	177	182	187	192	198	203
71	65	68	72	75	78	82	86	89	93	97	101	105	109	113	117	121	126	130	135	139	144	149	154	159	164	169	174	179	184	190	195	201	206
72	66	69	73	76	80	83	87	90	94	98	102	106	110	115	119	123	128	132	137	141	146	151	156	161	166	171	176	182	187	192	198	204	209
73	67	70	74	77	81	84	88	92	96	100	104	108	112	116	120	125	129	134	139	143	148	153	158	163	168	173	179	184	190	195	201	206	212
74	68	71	75	78	82	85	89	93	97	101	105	109	113	118	122	127	131	136	141	145	150	155	160	165	171	176	181	187	192	198	203	209	215
75	69	72	76	79	83	87	90	94	98	102	106	111	115	119	124	128	133	138	142	147	152	157	162	168	173	178	184	189	195	200	206	212	218

Horse's Length (in)